



**BHI**  
**HydroRam**  
**Hydraulic Hammer**

**HK580S**  
**Operation Manual**  
**& Parts List**

## **FOREWORD**

We thank you very much for your purchasing of our BHI HydroRam Hydraulic hammer.

To obtain the best performance of your hammer under any working conditions, you need to do proper handling, regular inspection and maintenance. Otherwise the hammer may fail to display its full capacity or result in various troubles of the certain parts.

This Operation Manual and Parts List provide you with all the information you need to correctly use for maintenance. Please read carefully this publications prior to the installation and operation in order to prevent any possible mishandling of the hammer and minimize the down time of the equipment. Any inquiry related to the maintenance and service through your local dealer will be highly appreciated.

BHI dealers and service workshops are equipped with the necessary special tools and well-dimensioned parts stocks where only genuine parts are used for service and repairs. We guarantee that a faithful compliance of the instruction will contribute to the best operational conditions. Customers are, therefore, required to keep in mind that the manufacturer is not responsible for troubles caused by not following our instructions or not using the genuine parts.

BHI reserves the right to make changes of the product without prior notice and without assuming any responsibility to carry out the same change to products already sold or manufactured.

Note! The descriptions in this book do not apply to any particular specification. Both standard and optional equipment are covered, and each hammer is equipped and set in accordance with each specific order. Consequently, standard and optional equipment are not marked in the text of this book.

**Best Hammer Industries  
Technical Information**

# INDEX

|  |    |
|--|----|
| <b>I. INTRODUCTION</b>                               | 1  |
| <b>II. SAFETY PRECAUTION</b>                         | 1  |
| 1. Safety Decals                                     | 2  |
| 2. Installation of Hammer                            | 4  |
| 3. Before Operation                                  | 5  |
| 4. Serial number marking position                    | 5  |
| 5. Tool Replacement                                  | 5  |
| 6. Hammer Operation                                  | 6  |
| <b>III. WARRANTY</b>                                 | 7  |
| 1. Delivery record                                   | 9  |
| 2. Claim application under warranty                  | 10 |
| <b>IV. TECHNICAL DATA</b>                            | 11 |
| 1. Standard Specifications                           | 11 |
| 2. Principles of Operation                           | 12 |
| 3. External Dimension - Power cell and Bracket       | 14 |
| 4. Construction - Excavator & Hammer Bracket         | 15 |
| 5. Torque Chart                                      | 16 |
| 6. Blow Speed & Power Control                        | 16 |
| <b>V. OPERATION AND HANDLING OF HYDRAULIC HAMMER</b> | 17 |
| 1. Hammer  | 17 |
| 2. Rules to Remember                                 | 19 |
| 3. Operator's Routine Maintenance                    | 23 |
| 4. Periodic Maintenance                              | 24 |
| 5. Factors of Tool Life                              | 24 |
| 6. N <sub>2</sub> Gas Pressure Maintenance           | 26 |
| 7. Nitrogen Gas Charging Pressures Table             | 28 |
| 8. Maintenance of Oil Filter                         | 29 |
| 9. Hydraulic Oil & Grease                            | 30 |
| 10. Maintenance Checking Schedule                    | 31 |
| <b>VI. TROUBLE SHOOTING</b>                          | 32 |
| <b>VII. ACCESSORY PARTS LIST</b>                     | 34 |
| 1. Tool type and parts list                          | 34 |
| 2. Union cap parts list                              | 35 |
| 3. Hose plug parts list                              | 35 |
| 4. O-ring adapter part list                          | 35 |
| 5. Base cover plate dimension                        | 36 |
| <b>VIII. UNDERWATER KIT(OPTION)</b>                  | 37 |
| <b>IX. AUTOLUBE KIT(OPTION)</b>                      | 38 |
| <b>X. WEAR PARTS AND JUDGMENT TOOL</b>               | 39 |
| <b>XI. PARTS LIST</b>                                | 41 |

## I. INTRODUCTION

BHI HydroRam Hydraulic Hammer, designed and built to provide durable operation under any working conditions, has been developed by BHI's excellent engineers with accumulated technology and experiences for many years.

This Manual contains safety, operation and routine maintenance instruction. It does not contain disassembly for service.

Do not operate the hammer unless the following safety instructions have been thoroughly read and understood. Read this Manual before installing, operating or maintaining the equipment.

Job applications are as below.

Construction sites:

Concrete demolition, general construction, rock breaking including trenching.

Mines & quarries:

Primary breaking and secondary breaking

## II. SAFETY PRECAUTION

Please familiarize yourself with the operating instructions and appropriate regulations before starting to work with the hydraulic hammer.

Safety notices in Operation Manual follow ISO and ANSI standard for safety warning.

### **DANGER**

Notices indicate an imminently hazardous situation which, if not avoided, would result in death or serious injury.

### **WARNING**

Notices indicate a potentially hazardous situation which, if not avoided, could result in death or serious injury.

### **CAUTION**





Notices indicate a potentially hazardous situation, which, if not avoided, may result in minor or moderate injury.

### **ATTENTION**

Notices in BHI Operation Manuals are an BHI standard to alert the reader to situations which, if not avoided, could result in the equipment damage.

WARNING and BASIC OPERATION INSTRUCTIONS decals are included with each BHI hammer and operation kit. Decals must be installed on the hammer bracket.

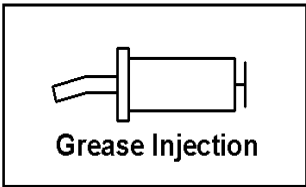
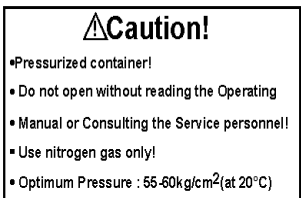
## 1. Safety Decals

|   | Sticker   | Description                        | Instruction   |
|---|---|------------------------------------|---|
| 1 |    | Head wearing, ear protection       | Use hearing protection                                |
| 2 |    | Operation Manual<br>Service Manual | Read the manual before use                            |
| 3 |   | Warn a danger nearby<br>job sites. | Keep away the breaking area<br>while the hammer works |
| 4 |  | Grease Injection                   | Inject grease   |
| 5 |  | Caution                            | Gas Pressurized Container                             |
| 6 |  | Lifting                            | Holder Position                                       |

HK580S DECALS LIST

| Item | Model                | HK580S   |
|------|----------------------|----------|
| 0    | DECAL KITS           | DM695200 |
| 1    | CE                   | DM301200 |
| 2    | MODEL                | ML301210 |
| 3    | HYDRORAM             | D7301220 |
| 4    | WARNING              | D1301230 |
| 5    | READING              | D1301240 |
| 6    | LIFTING              | D1301250 |
| 7    | CAUTION— for Low P.  | D4301260 |
| 8    | CAUTION— for High P. | D9301260 |
| 9    | GREASE INJECTION     | D1301280 |
| 10   | CYLINDER ADJUSTER    | DK301290 |
| 11   | ON-OFF VALVE         | DK301300 |
| 12   | ADJUSTER VALVE       | DK301310 |
| 13   | AEM MEMBER           | DK000530 |

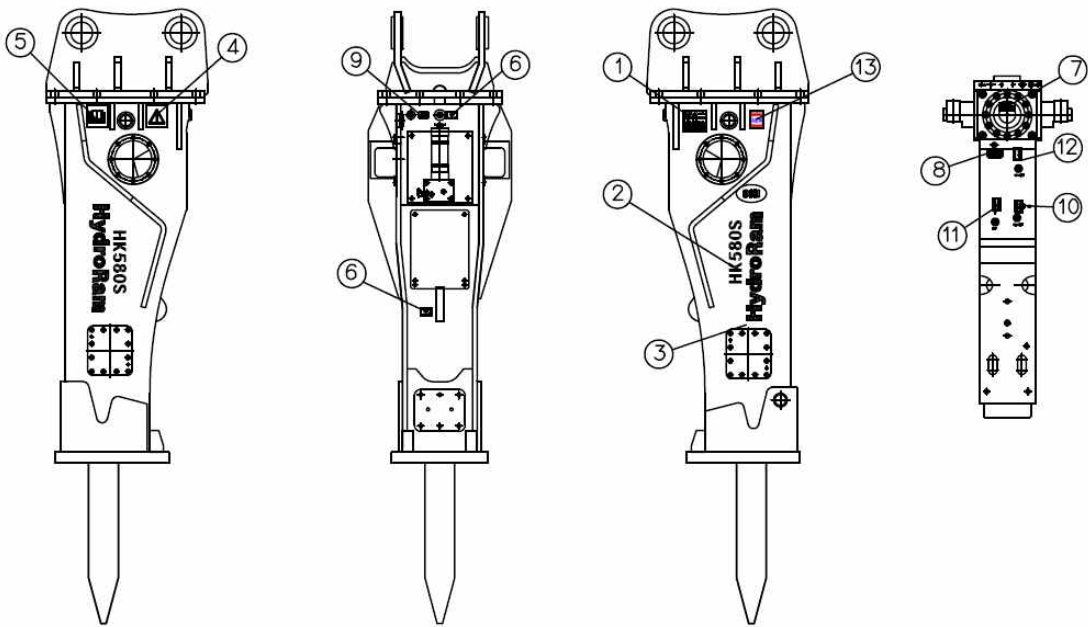

DETAIL ①

# HK580S HydroRam

DETAIL ②

DETAIL ③



DETAIL ④



DETAIL ⑤



DETAIL ⑥



DETAIL ⑦



DETAIL ⑧



DETAIL ⑨



DETAIL ⑩



DETAIL ⑪



DETAIL ⑫



DETAIL ⑬

## ATTENTION

### 2. Installation of Hammer

- 1) When installing the hydraulic hammer, an assistant who must be instructed by the carrier operator is required. All directions and signals, etc. must be understood and agreed on beforehand.
- 2) Only lifting equipment like crane should be used for transporting the hydraulic hammer.
- 3) The hydraulic hammer should be installed to the carrier with sufficient load capacity. If the carrier is too light, it may become unstable and fall over.
- 4) Keep linkage and pin holes clear when installing the hydraulic hammer. Do not touch any parts when the boom is moving. Never use your fingers to check the alignment of the linkage.
- 5) Collect any oil which leaks out and dispose of it correctly.
- 6) Operation of the hydraulic hammer requires the installation of hydraulic pipe lines for exclusive use of the hydraulic hammer.
- 7) The hydraulic system to the carrier must be checked by the authorized service engineer before first operation and after any modifications.

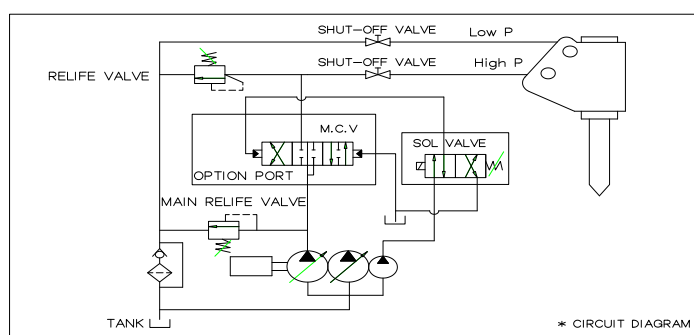

- 8) After installation of hydraulic pipe lines, check the pressure and oil capacity. Check the relief valve on the hydraulic system, which secures high pressurized accumulator. It must have been approved by the relevant authority. Make sure that the pressure of relief valve has been set correctly, i.e. to the maximum permissible operating pressure of the hydraulic hammer.

| Model                   | Unit                       | HK580S       |
|-------------------------|----------------------------|--------------|
| Relief Setting Pressure | Kg/cm <sup>2</sup> / [psi] | 210 / [2985] |

\* The above relief setting pressures are subject to change - efficiency of the pump.

- 9) Check the connections of the hydraulic hammer and the hammer hoses.
- 10) The connecting threads must be undamaged and free of sand or similar foreign body.

**⚠ DANGER**

### 3. Before operation

- 1) Check the level and contamination of hydraulic oil in the hydraulic oil tank of the carrier. In case oil is not sufficient, please fill up the same oil and never mix up oils from different manufacturers. Also if it is contaminated, drain it and fill up with new one.
- 2) Make sure the shut-off valve is completely open.
- 3) Check for looseness of threads of hose, all kinds of bolts and nuts and re-tighten securely.
- 4) Grease the shank bore 5 - 6 times by the hand grease pump.
- 5) Warm up the engine of carrier for five and ten minutes before hammer operation, especially in winter to reach the oil temperature to 30°C ~ 40°C(68°F ~ 104°F). Optimum oil temperature is 50°C ~ 80°C(59°F ~ 176°F).

### 4. Serial number marking position and Hose connection (High & Low pressure)

Left: high pressure(In-let) line, Right: low pressure (Out-let) line

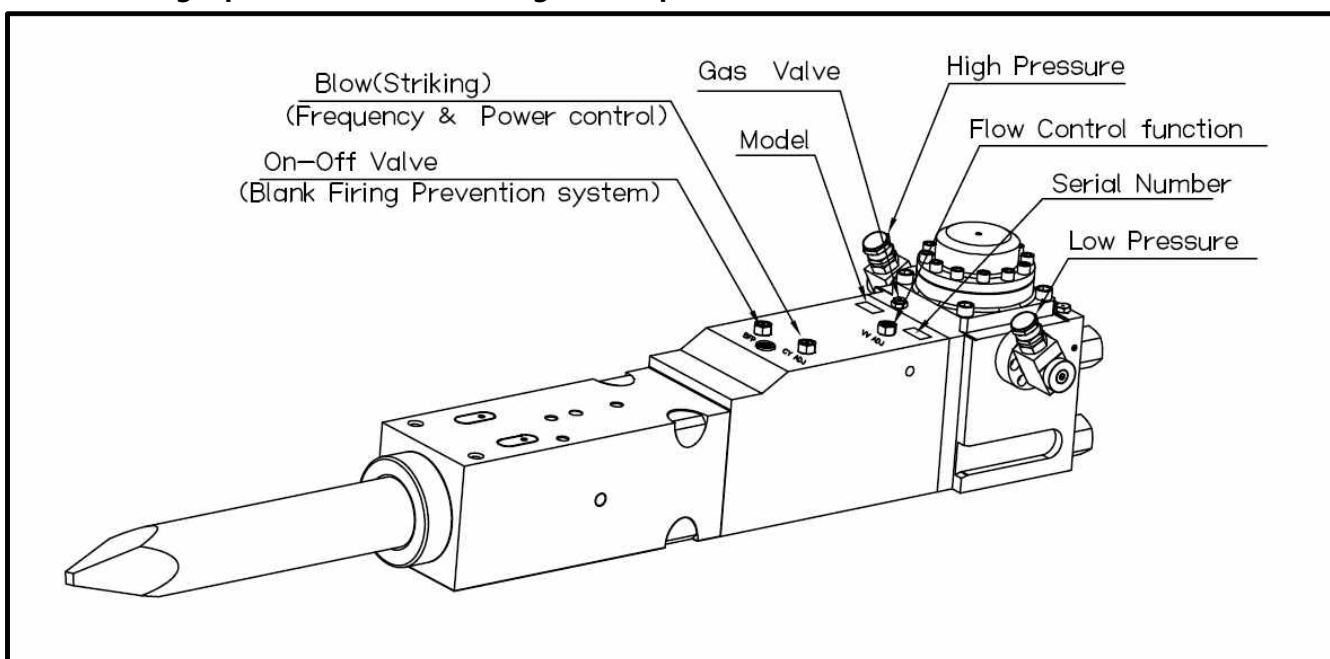

## ATTENTION

### 5. Tool Replacement

- 1) Always wear the protective glasses and helmet when fitting/removing the tool since metal chips may fly off when the retaining bar is hammered out.
- 2) Never use your fingers to check the alignment of the recession in the tool to the oblong holes for the locking bars.

## ⚠ WARNING

### 6. Hammer Operation

- 1) Close the front screen and splinter protection apparatus on the cab to prevent



possible injury from flying debris during the hammer operation.

- 2) In normal operation, the critical cases - the critical noise level of 90 dB(A) is reached or exceeded, the machine operator and any other workers in the noise area must wear personal noise protection gear.
- 3) The hydraulic hammer should be operated only from the driver's seat and should not be put into operation until both carrier and hammer are in the correct position.
- 4) Shut off the hydraulic hammer immediately if anyone moves in the danger area, which is much larger for hammer operation than for carrier operation due to the risk of flying debris.
- 5) When working with a hydraulic hammer, operation of the carrier is governed by carrier manufacturer's safety regulations.
- 6) The hydraulic hammer is only suitable for the applications described. Never pry with the tools.
- 7) Check the oil temperature constantly to ensure it does not exceed 80°C. If higher temperatures are measured in the tank, an oil cooler must be fitted.
- 8) Flying debris from the hammer, tool, rock or other material may cause serious or fatal injury to the operator, personal protection equipment must be used.
- 9) When operating the hammer, ear, eye and breast protection appliance must be used at all time.
- 10) Do not operate the hammer in the underwater and mud without proper equipment.
- 11) Stop the engine before attempting to make any repairs, adjustment or servicing to either the carrier or the hammer.
- 12) Do not operate the carrier if you are under the influence of drugs or alcohol.
- 13) Remove hammer from carrier before the transport.
- 14) Before leaving the carrier, always lower the boom and insure the carrier is stable.
- 15) Never leave the carrier with the engine running.

### **WARNING** Danger of Explosion

- . N<sub>2</sub> gas cylinder should be used for charging gas into the accumulator and head cap.
- . Release all pressure prior to servicing or disassembly.
- . Do not open without reading the Manual or consulting the authorized service man!

Unauthorized repair work on the accumulator is forbidden. Defective accumulators must be replaced.

- . All accumulators are subjected to recurring tests by experts, at the latest after 5 years.

### **CAUTION**

All hydraulic oil brands used in the carrier units are suitable for operating. The use of other hydraulic fluids is only permissible after consulting with our service station. In summer and in regions with high temperatures, it is recommended that oils with a viscosity of category H-LP 36 or higher be used. At temperature lower than -20°C(4°F), the hydraulic

hammer should not be put into operation.

## ATTENTION

Apply grease at least once a day. Grease the tool bit at least every 2 or 3 hours more often if the tool becomes dry or material is extremely dusty or abrasive, using hand grease pump. Pump 5 - 10 times. When changing tool, clean and grease the shank bore. Insufficient greasing may cause abnormal wear of the tool holder bushing and tool, and tool breakage.

## WARNING

Injury or death can result from improper operation or maintenance.  
Please read and understand this Operation Manual!!!

## ATTENTION

**Preserve the environment !!!**

When dispose of the waste Hydraulic Hammers, obey all local, state of federal regulation for the industrial waste.

### III. WARRANTY

Warranty period is six(6) month. Below parts are wear parts. These parts are not covered by the warranty.

Wear parts : Diaphragm, Backup Ring, Buffer Ring, O-Ring, Round Bushing, Stop Pin, Spring Pin, Tool Holder Bushing, Retainer Pin, Tool and Seal Kit sets.

The warranty condition could be changed by individual contract, but it should be confirmed in writing by BHI in advance.

## ATTENTION

### 1. The followings are not covered by warranty.

- . Normal wear and tear of the hammer and any part thereof
- . Failure, damage or defective condition due to:
  - overloading, negligence or improper installation, use or operation which are is not accordance with BHI's published instructions or its authorized distributors.
  - improper repair, alteration or adjustment made to Hydraulic hammer or its parts.
  - use of unauthorized parts, fluids or tools.
  - corrosion or failure to protect from adverse environmental conditions.
  - faulty or improper condition of the carrier on which the hydraulic hammer was installed.

## ATTENTION

### 2. After installation of the Hydraulic Hammer

After installing the Hydraulic Hammer, make sure if it is installed correctly and a copy Delivery Record with all signature should be mailed back to BHI.

When it is not and hammer is broken down, we are going to charge for the needed parts.

|                  |
|------------------|
| <b>ATTENTION</b> |
|------------------|

3. During under warranty

In case during under warranty you have problem with your hammer, the claim application under warranty form should be filled out and mailed to BHI.



Website : [www.bhice.com](http://www.bhice.com)

## Best Hammer Industries

5-91, Daepoong-ri, Daeso-myun, Eumsung-kun  
Choongbook-do, Korea

Tel: (82-43) 532 - 1370~1, Fax:(82-43)532-1372  
E MAIL: qa@bhice.com

### DELIVERY RECORD

To: \_\_\_\_\_  
 Owner: \_\_\_\_\_ Address: \_\_\_\_\_  
 Distributor: \_\_\_\_\_ Address: \_\_\_\_\_  
 Service Shop: \_\_\_\_\_ Address: \_\_\_\_\_  
 Model of Hammer: \_\_\_\_\_ Serial No.: \_\_\_\_\_ Delivery Date: \_\_\_\_\_  
 Model of Carrier: \_\_\_\_\_

#### A. Checked on the following items: Symbol for inspection

Normal :V, Clean :C, Adjust :A, Disassembly :D, Refill gas :G  
 Lubricate :L, Repair :M, Replace :R, Tighten :T, Not remedied :X

1. Hammer body:     Accumulator gas pressure             Operating pressure  
                           Head cap gas pressure                             Operating sound  
                           tool Holder lubrication                             Oil leakage  
                           Rubber plugs
2. Bracket Frame:     Bolt looseness     Pins lubrication
3. Piping:             Tightening of fittings     Fully opened shut-off valve  
                           Oil leakage     Relief valve set pressure
4. Controls:             Adjustment of control cable     Pins lubrication  
                           Engine throttle lever position     Caution at operation sticker
5. Carrier pump:     Characteristics     Performance
6. Hydraulic oil:     Quantity of oil     Deterioration  
                           Contamination
7. Standard tools:     Quantity
8. Manuals:             Operation manual & Parts list

#### B. Instructed proper operation and maintenance procedures.

The owner's signature below acknowledges that the hammer above mentioned was delivered to him in a satisfactory condition and he has received proper instruction about the operation and maintenance.

Purchaser signature: \_\_\_\_\_ Date: \_\_\_\_\_

Distributor: \_\_\_\_\_ Serviceman: \_\_\_\_\_



**Best Hammer Industries**

5-91, Daepoong-ri, Daeso-myun, Eumsung-kun  
Choongbook-do, Korea

Tel: (82-43) 532 - 1370~1, Fax:(82-43)532-1372  
E MAIL: qa@bhice.com

Website : [www.bhice.com](http://www.bhice.com)

**CLAIM APPLICATION UNDER WARRANTY**

- 1. Model & Serial No.:
- 2. Date of Installation :

|                         |  |                     |  |
|-------------------------|--|---------------------|--|
| 1) Manufacturer & Model |  |                     |  |
| 2) Oil supply(gpm)      |  | 3) Working Pressure |  |
| 4) Return Pressure      |  | 5) Relief setting   |  |

- 3. Carrier:

To insure efficient operation, it is essential that complete and proper hydraulic adjustments have been verified at the time of the installation. Refer to your operation manual for the methods of performing these tests and record the readings that you find on this card. Failure to supply this information or to use BHI parts and tools may result in forfeiture of warranty coverage.

**IV. TECHNICAL DATA**

|   |  |   |          |           |      |
|---|--|---|----------|-----------|------|
| Dealer name:<br>Address:                              |  | Customer's name and address:                            |          |           |      |
| Completed by:   |  | Completed by:   |          |           |      |
| <u>Dealer</u>   |  | <u>Customer</u>   |          |           |      |
| -----<br>Dealer's Signature                      Date |  | -----<br>Customer's Signature                      Date |          |           |      |
| Details of Failure:                                   |  | Date of repair:   |          |           |      |
|   |  | Parts used for repair:                                  |          |           |      |
|   |  |   | Part No. | Part Name | Q'ty |
|   |  | 1   |          |           |      |
|   |  | 2   |          |           |      |
|   |  | 3   |          |           |      |

## 1. Standard Specifications

| Model               | Unit         | HK580S                     |
|---------------------|--------------|----------------------------|
| Recommended Carrier | Tons         | 40-65                      |
|                     | US Tons      | 44-72                      |
| Impact Energy Class | ft.lbs       | 14,000                     |
| Impact Frequency    | bpm          | L : 160-250<br>H : 250-350 |
| Working Weight      | kg<br>[lbs]  | 4,450<br>[9,790]           |
| Oil Flow            | lpm<br>[gpm] | 240-320<br>[63.4-84.5]     |
| Operating Pressure  | bar<br>[psi] | 160-180<br>[2,320-2,610]   |
| Tool Diameter       | mm<br>[inch] | 180<br>[7.09]              |
| Overall Length      | mm<br>[inch] | 3,805<br>[149.8]           |
| Hose Diameter       | inch         | 1¼                         |
| 85dB(A) Radius      | m            | 30-35                      |

- \* Specifications may be changed without prior notice.
- \* Operating Weight : Working Weight (Including Tool and Mounting bracket).
- \* When you want to install on the incorrect carrier which is beyond our recommended range, you must consult it with an authorized technical staff. If not, the hammer may have major problems.

## 2. Principles of Operation

The relation between the area(A2) affecting the pressure from the upper chamber of the piston and the area(A1) affecting the pressure from the lower chamber of the piston is  $A2 > A1$  and high pressure applies to A1. When A2 changes from high to low pressure or vice versa, piston (E) reciprocates. Inside of head cap is charged with the high pressure N<sub>2</sub> gas and gas energy stored in the upstroke of the piston (E) effectively acts on the piston (E) during the impact.

### 1) Upstroke of Piston

As high pressure always applies to A1 and A2 changes to low pressure, the force affects the Piston(E) upward until it reaches to Cylinder Converting Port(P2). While Piston(E) moves upward, it is compressing the gas contained in the head cap chamber. As high pressure applies to Valve High Pressure Port(B1,B2) and Valve Converting Port(B4) converts to low pressure, Valve(K) remains in the down position.

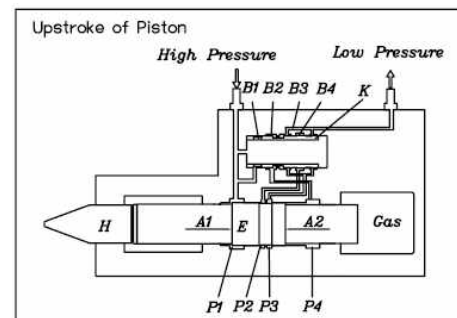

### 2) Valve Shift

When the area (A1) of the lower chamber of the Piston(E) reaches to the chamber of the Cylinder Converting Port(P2), the chamber of the Cylinder Converting Port becomes and remains high pressure. Cylinder Converting Port(P2) communicates with Valve Converting Port(B4) and delivers the high pressure oil. When the area(V1) of the Valve Converting Port(B4) applies to high pressure, Valve(K) moves upward and shifts. Then Valve High Pressure Port(B2) communicates with Upper Port(P4) of the Piston and oil being pressurized is admitted to Upper Chamber of the Piston.

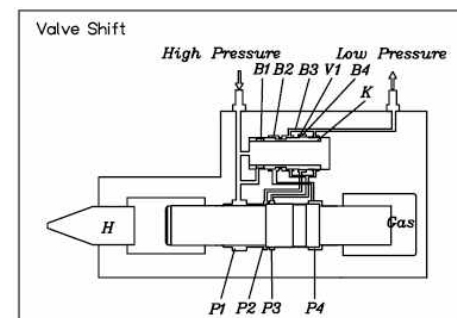

### 3) Power Stroke

The difference of the area  $A1 < A2$  makes the Piston(E) move downward until Cylinder P2 Port communicates with P3 Port. When the Piston(E) comes down, its descending speed is accelerated by the pressure of gas in the Upper Chamber of the Piston.

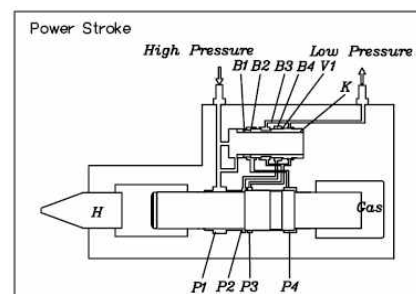

### 4) Impact

Kinetic energy obtained by the Piston during the power stroke is transmitted to the tool(H) and then impact energy required to break is transmitted to the rock. After that, Piston starts to move upward again.

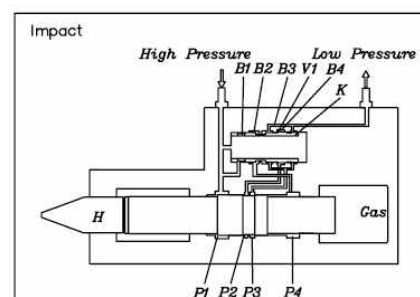

B1 : Valve High Pressure Port  
 B2 : Valve High Pressure Chamber  
 B3 : Valve Low Pressure Port  
 B4 : Valve Converting Port  
 V1 : Valve Converting Area  
 Gas : N2 gas Chamber  
 K : Valve

P1: Cylinder High Pressure Port  
 P2: Cylinder Converting Port  
 P3: Cylinder Low Pressure Port  
 P4: Upper Port of the Piston  
 H: Tool  
 E: Piston



3. External Dimension - Power cell and Silence Bracket

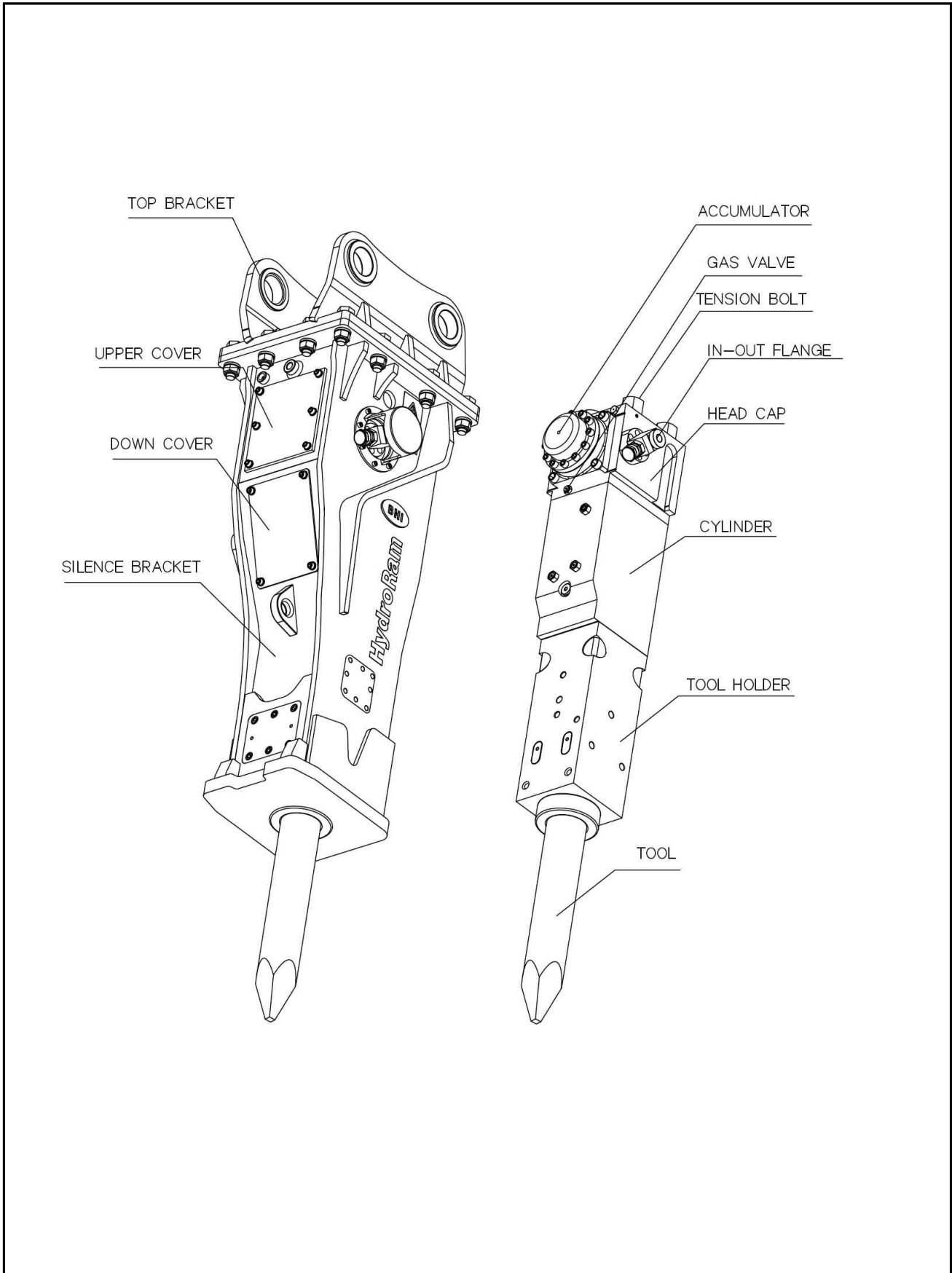

4. Construction - Excavator & Hammer Bracket

. Top mounted and silence mounted bracket on excavator  
must connect with hydraulic pipe lines.

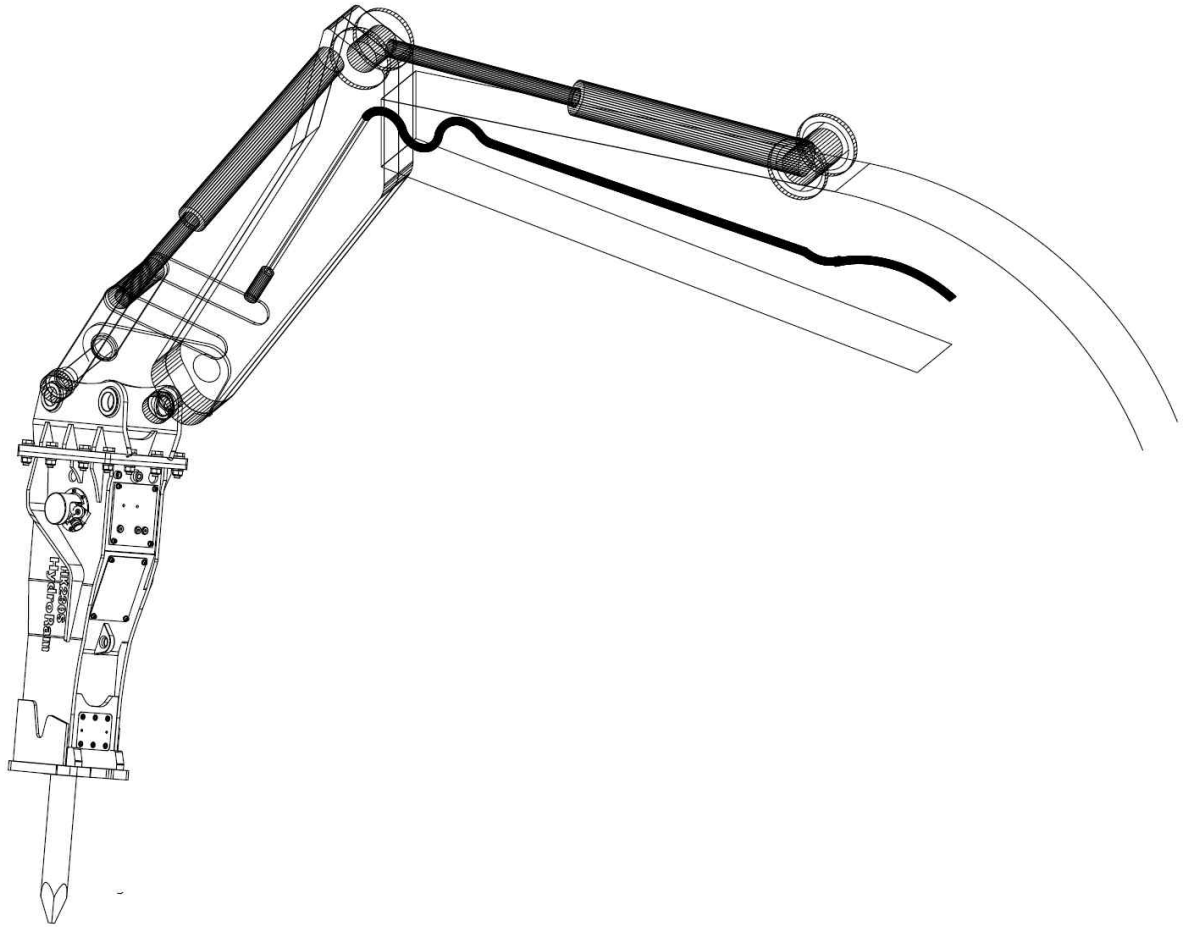

## 5. Torque Chart

[ Units: kg.m / N.m] / lb-ft ]

| Item                      | Torque                         |
|---------------------------|--------------------------------|
| Tension Bolt              | 480kg.m / 4707N.m / 3471 lb-ft |
| Accumulator Cover Bolt    | 85kg.m / 833N.m / 614 lb-ft    |
| Accumulator Assembly Bolt | 170kg.m / 1667N.m / 1230 lb-ft |
| Mounting Bolt             | 300kg.m / 2943N.m / 2170 lb-ft |

## 6. Blow Speed &amp; Power Control

## 1) Blow Speed Control (Adjuster Valve)

(1) Standard turn initially set at the factory means turning the adjuster counterclockwise after being completely locked.

(2) Initial (standard) turn [Initial turn/(Total turn)]

|       |        |
|-------|--------|
| Model | HK580S |
| Turn  | 2 (10) |

In case faster speed is needed than basic turn,  
B direction => turn it counterclockwise  
In case of slower speed is needed,  
A direction => turn it clockwise

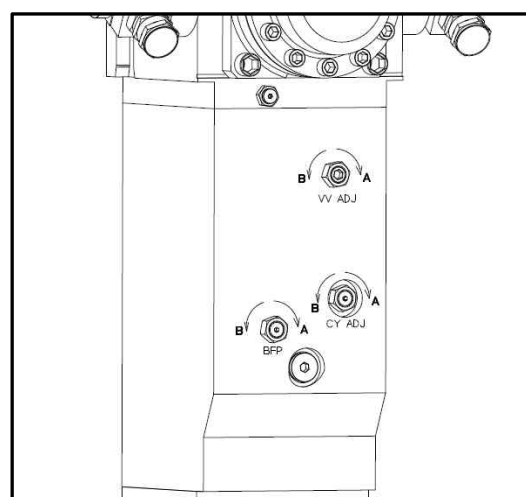

## 2) Blow(Striking) Frequency &amp; Power control ( Cylinder Adjuster Valve )

(1) Initial (standard) turn [Initial turn/(Total turn)] : 2 Turn

In case faster speed is needed than basic turn,

B direction =>Max. 2 turn it counterclockwise

In case of slower speed is needed,

A direction => turn it clockwise



**DO NOT TURN THE CYLINDER ADJUSTER MORE THAN TWO(2) FULL TURNS FROM ITS SEATED POSITION OR IT MAY BLOW OUT OF THE HAMMER CAUSING INJURY OR DEATH TO ANYONE IN THE VICINITY!**

## 3) Blank Firing Prevention system

(1) Initial (standard) turn [Initial turn/(Total turn)] : 0 Turn

(2) In case of Blank Firing Prevention system :

B direction => Max. 2 turn it counterclockwise

## V. OPERATION AND HANDLING OF HYDRAULIC HAMMER

### 1. Hammer

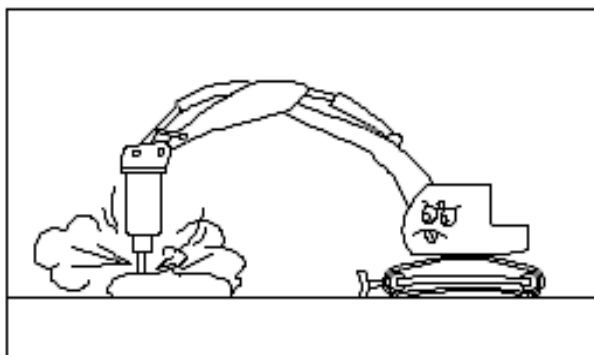

#### ATTENTION

##### 1) Proper Positioning

The hammer must be positioned perpendicular to the material. It is especially important to follow this rule when using the hydraulic hammer so that it can correctly test the hardness of the material. If it is improperly aligned, it could respond as though it was working in light material and remain in a high frequency, low impact mode. When it is properly aligned, it selects best frequency impact combination for maximum performance with that material at that particular time. When installing a new Hammer, it is recommended that the Hammer is run in vertical position at about 250~300 blow per minute for one hour. Also after 10 minutes working start is recommended. During that time avoid Hammering in inclined condition. If the frequency is fast, the impact is low. If the frequency is slow, the impact is high.

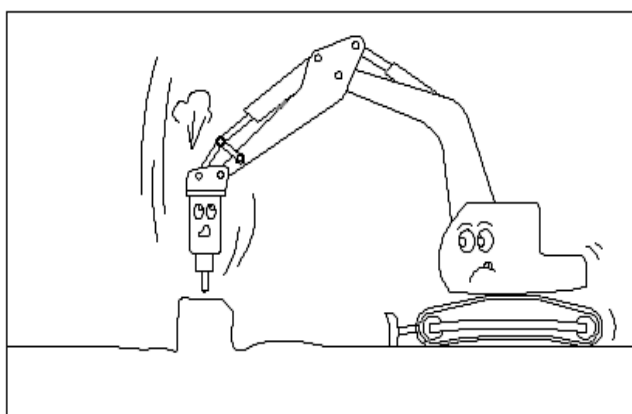

##### 2) Applied Pressure

All hammers must have sufficient pressure against the tool to allow the transmission of energy, or the shock wave to flow through the tool to the material being broken. As the tool moves through the material, applied pressure is continuously adjusted by using a combination of the boom, dipper and attachment controls so that the hammer follows the tool.

#### CAUTION

##### Applied Pressure Must be Correct

If applied pressure is insufficient, the tool will dance around on the material rather than sending energy into the rock. When this happens, impact created by the piston is not transmitted to the rock as a shock wave but is absorbed by the hammer and excavator causing abnormal structural fatigue.

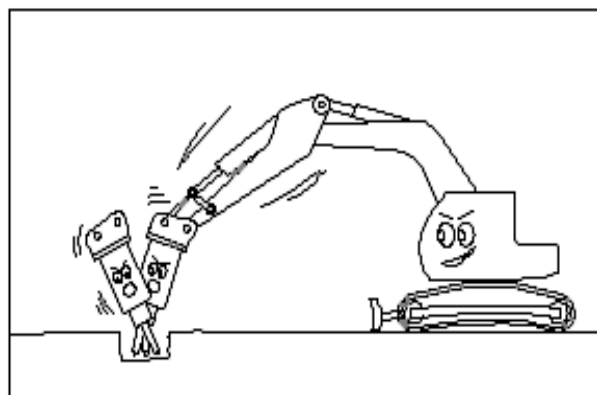

Applied pressure should not lift the carrier

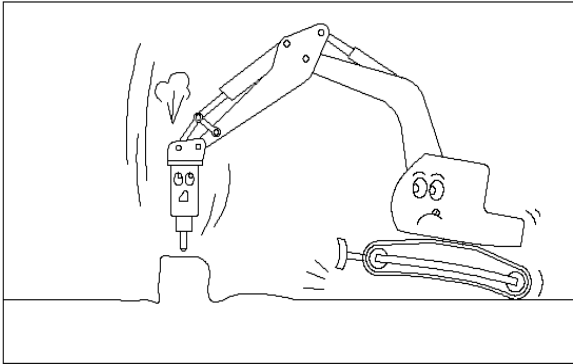

high off the ground. As the hammer breaks through the material, the excavator will drop suddenly and harmful shock loads will be transmitted to the tool, power cell and excavator. If the hammer is too heavy for the carrier, the resulting damage will be worse. So it is important to proper size of the hammer to the carrier.

### 3) Secondary Breakage of Boulders

**ATTENTION**

" Short Bursts = Better Production = Long Tool Life "

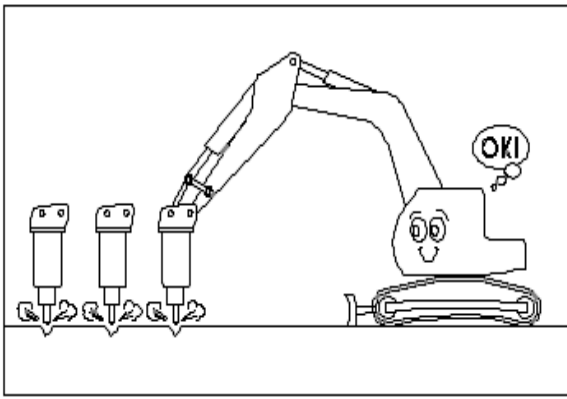

When breaking large rocks, do not attempt to break them from the center. It is more efficient if breaking is done from the edge. Take small bits and do not work on one spot for more than 30 seconds. This method will increase your productivity and cause less wear and tear on your equipment.

### 4) Surface Rock Demolition

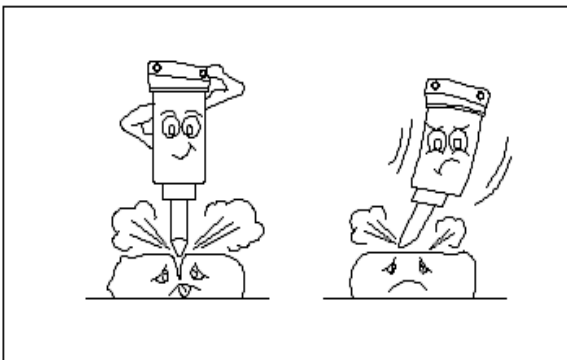

Do not try to break too much at one time. It is wiser to start from the edge and work towards the center.

## ⚠ CAUTION

**Stop Immediately When  
The Hydraulic Hoses Jerk Violently.**

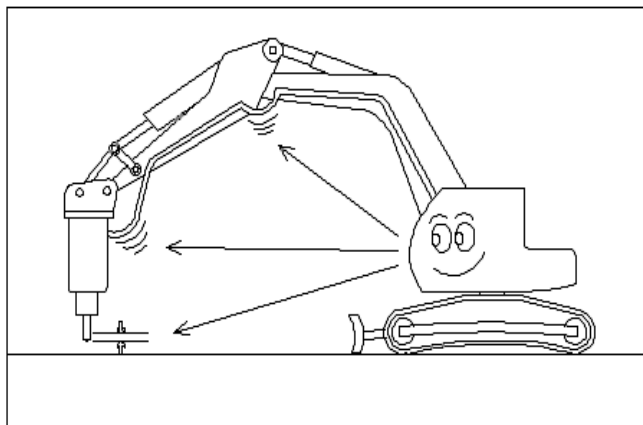

clean and lubricate the shank for installation of the tool.

Abnormal surging means the nitrogen accumulator is empty. Stop the hammer immediately and repair the accumulator.

### The Tool Does Not Drop.

If the visible length of the tool does not change, it usually means the tool has seized in the bushing. Remove the tool and check the bushing. If obvious signs of seizing are present, remove the marks from the tool and bushing or replace as necessary. Then

### Tension Bolt is Loose Or Broken.

Tighten it properly or replace it. You can tell if it is broken or loose by tapping on the bolt and listening for a distinctive high pitched sound.

## ATTENTION

### 2. Rules to Remember

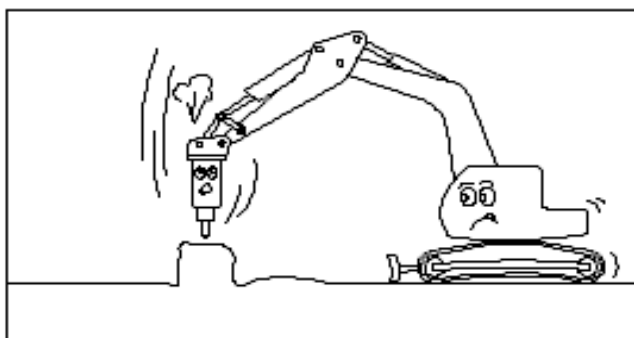

#### 1) Avoid Blank Hammering At All Times.

If this happens, the piston will strike the tool shank with full impact, forcing the tool against the retainers and causing premature wear and failure to the tool, tool retainers, piston, chuck housing, tension bolts and the hammer itself. And since there is no material to absorb the energy, the shock waves will bounce back up the tool, meeting other waves coming

down the tool in violent collisions. These collisions create a disorganized mass of energy, causing extensive wear and tear to the tool and other hammer components.

**2) Never Use A Hammer For Activities For Which It Was Not Designed.**

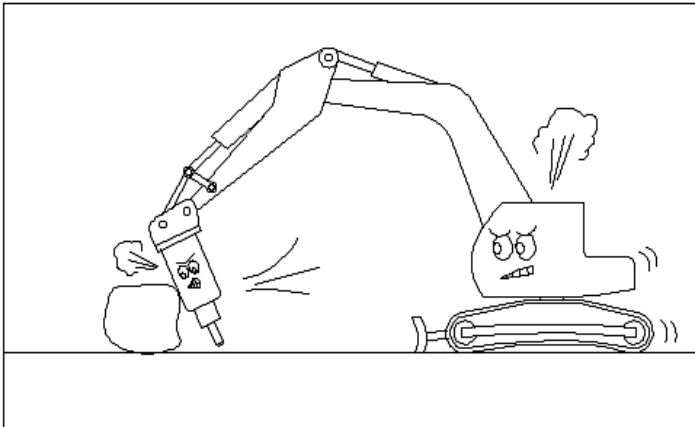

Insure your hammer features this capacity are normally fitted with a rock hook or some type of protective structure around the chuck housing.

**3) Do not use the tool or hammer space as a lifting device.**

Not only this is dangerous, but also it can cause damage to the hammer, tool and bushings.

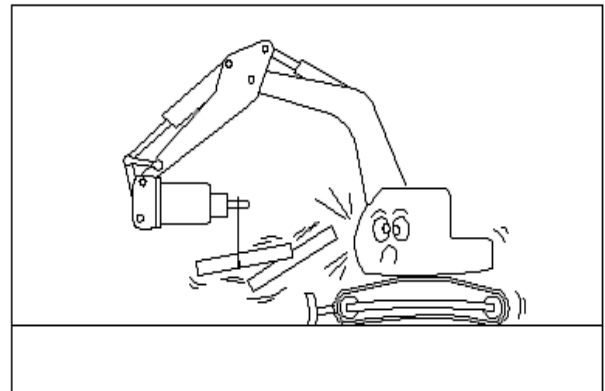

**4) Do Not Pry Under Any Circumstances.**

Prying is the most common cause of tool breakage. It also causes damage to other hammer components as well as reducing productivity. Prying inhibits of the shock wave through the tool and creates heat buildup in the bushing area.

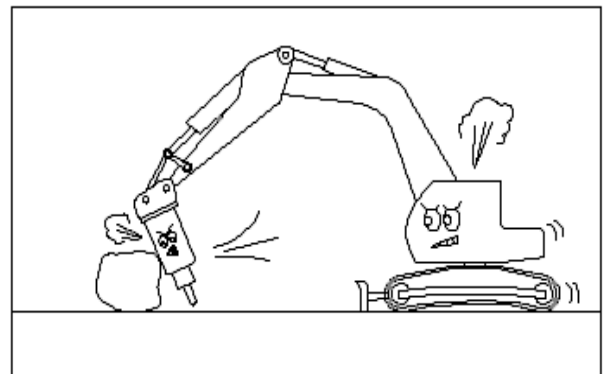

**5) In Cold Weather, Always Warm Your Equipment Up Properly Before Operating**

After the carrier is warmed up, suspend the hammer in the air (with the tool extended) to activate the automatic stop. Activate the control to circulate the oil and warm the hammer. Warm the tool bit by operating at slow speeds for five to ten minutes. During extremely low temperatures, store the tool inside.

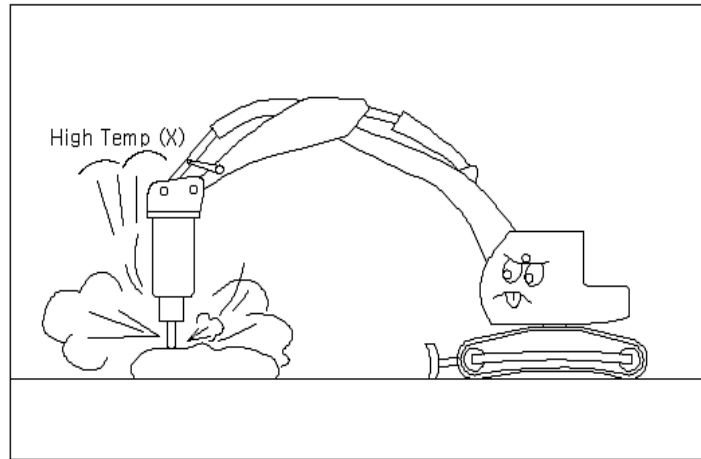

**6) Do Not Allow Cylinders To Reach The End Of Their Stroke**

They will not endure the hammer vibrations in this position.

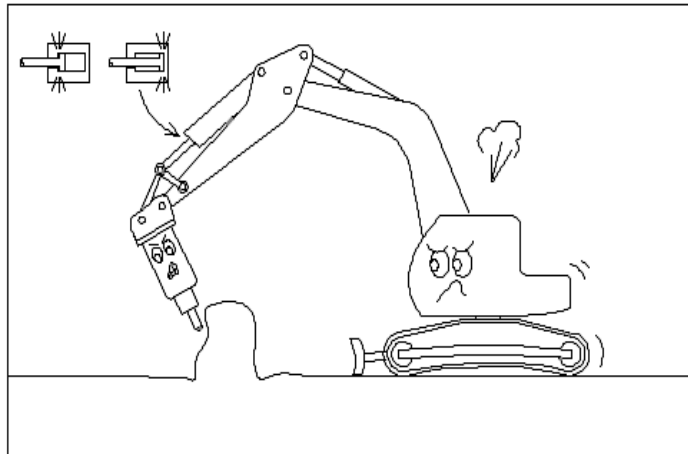



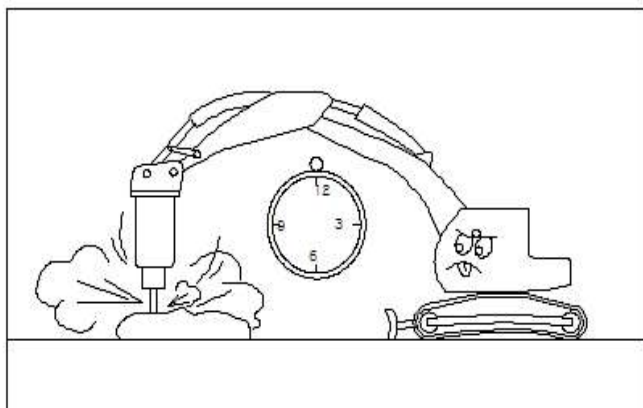

**7) Never Let The Hammer Strike On The Same Spot More Than 30 Seconds.**

Even 30 seconds can be too long for large Hammers. Working in one spot too long causes heat buildup in the tool, resulting in loss of tool strength and wear resistance.

A power can build up under the tool and dampen the shock wave travelling through the tool and into the material. Move the tool often to avoid this effect.

**9) Do not immerse the hammer into water or mud.**

When components except tool are immersed in water and mud, piston and other components may be rusted and become damaged at an early stage.

**⚠ WARNING**

\* For under water operation, please contact us.(option)

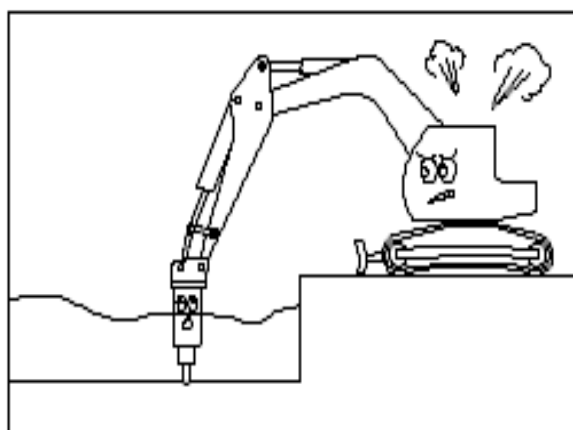

**8) Moves The Tool to New Positions Often.**

**10) Do not touch the tool and hammer body.**

During hydraulic hammer operation, it can reach high temperatures.

**⚠ WARNING**

**11) Do not open Accumulator bolt**

Accumulator is a high pressurized N2 gas container.

## ATTENTION

### 3. Operator's routine maintenance

#### 1) Lubrication

Grease the tool and bushings every two to four hours of operation, more than often in dusty or severe conditions, with five to ten pumps of good quality, high temperature grease.

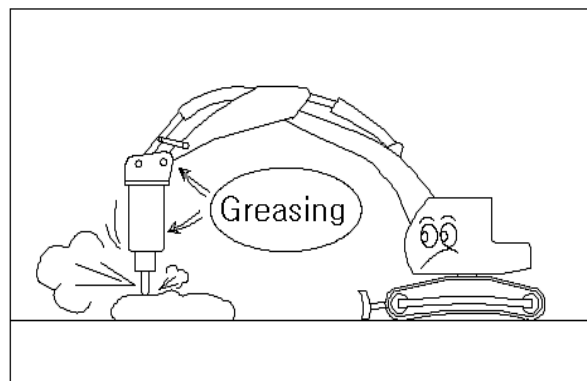

## ATTENTION

### 2) Inspection Points:

#### (1) Visual Inspection.

Check welds for possible cracks on the bracket cap, rear, tool and boom.

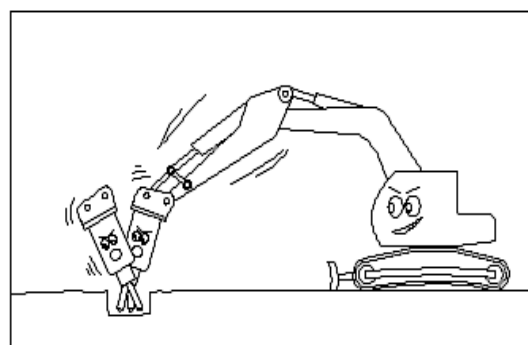

#### (2) Check for loose nuts and bolts.

- (1) In the bracket cap
- (2) In the charging valve
- (3) In the accumulator
- (4) In the side plates
- (5) In the tool holder pin

#### (3) The tool retainer pins

When replacing tool retainer pins always replace them in sets and rotate them equally.

#### (4) Excessive oil leakage down the tool

This is an indication of worn or damaged seals that need to be replaced.

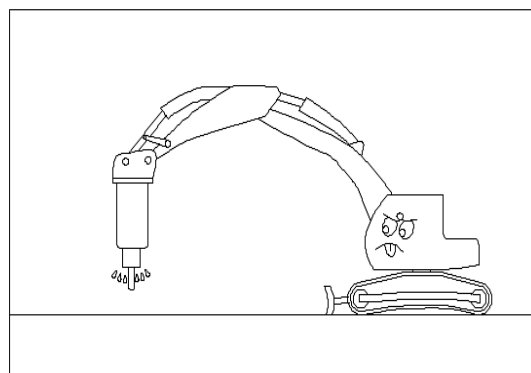

|  |
|--|
|  <b>CAUTION</b> |
|--|

#### 4. Periodic Maintenance (Every 100 hours)

##### 1) Remove the tool and all grease from the tool holder bushing

Do not use a pressure washer, steam, or solvents as they damage the seals. Check for chips or cracks inside the housing and on the bushing surfaces. Cracks and chips could indicate that:

- (1) Lubrication is insufficient
- (2) Grease type is not appropriate
- (3) Blank hammering and side loading is occurring and hammer is being operated improperly.

##### 2) Check wear on tool pin

Examine the shoulders and side surface. If they are worn or deformed, rotate or replace as required.

##### 3) Check wear on tool holder bushing

Replace tool, tool holder Bushing or both where the combined wear exceeds 5mm. Some Bushings are grooved to provide even grease distribution. Replace the Bushings when the grooves are worn through. Excess tool holder Bushing wear causes tool misalignment to the piston, causing premature hammer failure.

##### 4) Replace damaged or worn parts

Then wipe all components clean, including the lubrication port. Hand grease the tool shank and inside the chuck bushings before placing it back into the hammer.

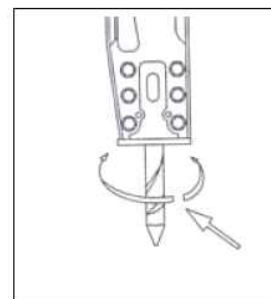

#### 5. Factors of Tool Life

##### 1) The type of work ( Twisting action )

Breaking reinforced concrete, for instance, is more detrimental to tool than concrete without rebar. Twisting action caused by the flat edge of the tool against the tool and retainers.

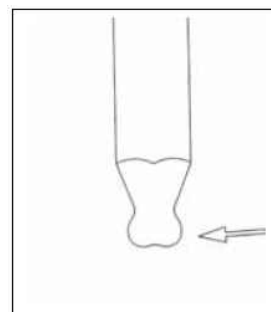

##### 2) The type of rock

A particularly abrasive rock will wear the tool out faster than less abrasive material. Certain types of rock turn to powder which cushions the impact. This could cause the tool to overheat and mushroom.

3) Blank hammering will chip tool on the top and in the retainer area. These chops accelerate wear and tear on the tool, retainer pins, round Bushing, and the piston.

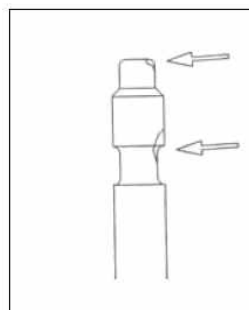

4) Proper lubrication at all times.

Lack of lubrication will increase the temperature in the bushings and tool shank which ultimately causes deterioration of these components.

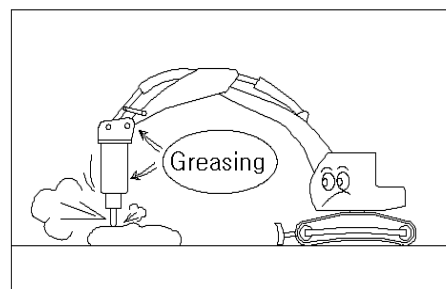

## ATTENTION

### ◆ COMMON TOOL ABUSE

- . Side loading
- . Improper warm-up
- . Untrained operator
- . Heat build-up from working in one spot.
- . Rapid cooling by submersing in water.
- . Excessive wear on bushings and retainers
- . Machine movement
- . Blank hammering
- . Prying
- . Drilling
- . Tool deflection

## ATTENTION

◆ **Replacement of Tool:** When a tool bit is worn out, it is liable to slip. Then, sharpen the tip. But when grinding the tip many times to sharpen the edge, the hardened surface layer would cut off and it makes the rod to be worn out rapidly. When the difference gap between tool holder and tool holder bushing is over 6 mm, then replace tool holder together with the tool.

### ◆ REPLACEMENT OF TOOL

- . Put the steel bar supplied into the hole of stop pin and hit the stop pin on the opposite side by hammer.
- . Use the steel bar and hit the retainer pin on the opposite side by hammer.
- . Push out both of the retainer pins by hammering and pick out tool. The tool is heavy, so careful attention is required.
- . Reverse disassembly procedures to install a replacement of the tool.

## ⚠ WARNING

## 6. N<sub>2</sub> gas Pressure Maintenance

### 1) Inspection of N<sub>2</sub>Gas Pressure Inside Head Cap ( same as the Accumulator )

- (1) Remove the cap from the gas valve.

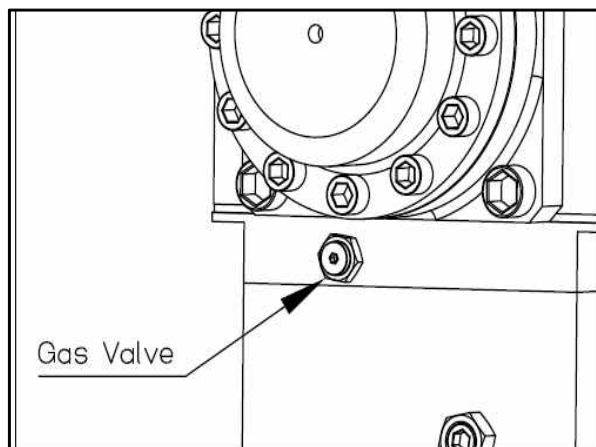

- (2) Turn the handle of gas charging adapter counterclockwise until it stops.
- (3) Connect the gas charging adapter with gas valve.
- (4) Fix the cap of gas charging adapter after turning it clockwise.
- (5) Turn the handle, so that gas pressure inside head cap is indicated on the pressure gauge.

### ATTENTION

- . Gas pressure changes according to the position of the tool. Lay down the hammer and let the tool extend fully.
- . If it is not optimum gas pressure, it should be set according to the chart as below.

### ⚠ DANGER

- ◆ Head cap & Accumulator Optimum Nitrogen Gas Pressure [kg/cm<sup>2</sup>(psi), at20°C(68°F)]

### 2) Removal of gas charging adapter

- (1) Turn the handle of gas charging adapter counter clockwise until it stops.
- (2) Unscrew the cap and release the gas inside the gas charging adapter.
- (3) Remove the gas charging adapter from the gas valve and fit the cap of gas valve.

### 3) How to set the gas pressure

- (1) If you loosen the cap slowly after taking the above procedures, the gas pressure will become lower. Tighten the cap at the optimum pressure.
- (2) Next procedures are same as removal procedures of gas charging adapter.

### 4) Filling N<sub>2</sub>Gas

Take the following procedures after of Inspection of N<sub>2</sub>gas pressure inside head cap mentioned above.

(1) Connect the charging hose to N<sub>2</sub> gas cylinder.

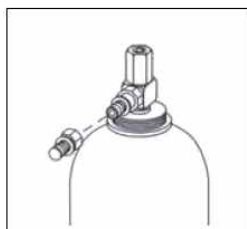

(2) Remove the cap of the gas charging adapter and connect to charging hose. Turn the handle clockwise to tighten.

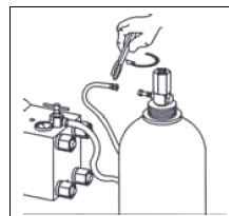

(3) Open the main valve of gas charging cylinder counterclockwise to reach the pressure gauge to optimum pressure. Close the cap clockwise to stop the gas filling.



(4) Turn the handle of gas charging adapter clockwise and stop when the pressure gauge indicator moves.

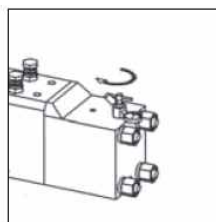

(5) Open the main valve of gas charging cylinder slowly counterclockwise again to refill the gas up to optimum gas pressure, reading the gauge indicator.

(6) When the optimum gas pressure is obtained, close the main valve of gas charging cylinder by screwing clockwise. Also turn the handle of gas charging adapter counterclockwise not to leak out. Remove the gas charging adapter finally.

#### 5) Inspection of accumulator

If there is a big tremor on the hose of high pressure line, it means that accumulator does not work. Stop the operation and inspect the accumulator.

### **CAUTION**

- ◆ Pressurized container! Do not open without reading the Operation Manual or consulting the authorized service personnel!

### **ATTENTION**

#### 7. Nitrogen Gas Charging Pressures Table

### **CAUTION**

Depend upon AMBIENT Temperature

1) N<sub>2</sub> Gas Charging Kit Parts List

| No. | Part No. | Part Name                               | Q'ty |
|-----|----------|---|------|
| 0   | DA698000 | N <sub>2</sub> GAS CHARGING KIT         | 1    |
| 1   | 13105900 | N <sub>2</sub> GAS 3-WAY VALVE ASSEMBLY | 1    |
| 2   | 16802000 | N <sub>2</sub> HOSE                     | 1    |
| 3   | 13105910 | N <sub>2</sub> COUPLING KIT             | 1    |
| 4   | 13105920 | N <sub>2</sub> GAS CYLINDER             | 1    |
| 5   | DF300520 | EXTENSION STICK ( OPTION)               | 1    |

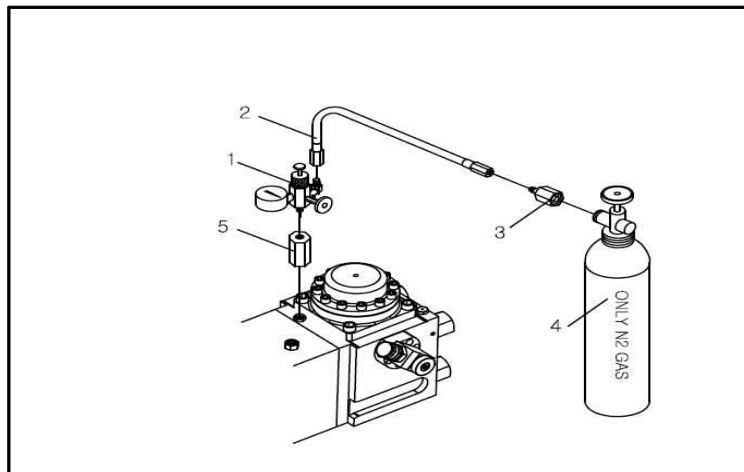

2) Head Cap Part ( Low Pressure)

| Temp |    | Model     |                           |
|------|----|-----------|---------------------------|
|      |    | HK580S    |                           |
| °C   | °F | PSI       | kg/cm <sup>2</sup> (≒bar) |
| 20   | 68 | 242 ~ 256 | 17.5±0.5                  |

3) Accumulator Part ( High Pressure )

| Temp |    | Model   |                           |
|------|----|---------|---------------------------|
|      |    | HK580S  |                           |
| °C   | °F | PSI     | kg/cm <sup>2</sup> (≒bar) |
| 20   | 68 | 782~852 | 55.0~60.0                 |

**ATTENTION****8. Maintenance of oil filter**

Contaminated oil results in malfunctions of the hammer as well as carrier and cause damage to parts. Pay special attention to oil contamination.

Contaminated oil should be changed without delay. When changing oil, thoroughly wash oil tank, cylinder and pipes. Cleaning or replacing oil filter also requires check for oil contamination. Replacement of filter: first 50hours and every 100 hours thereafter. Replacement of hydraulic oil: every 500 hours.

An oil filter must be fitted in the return line of the hydraulic system with a mesh of no greater than 50 micrometers and a magnetic separator.

**⚠ CAUTION**

Preserve the environment from the ravages of pollution : When dispose of the waste Hydraulic Hammers, obey all local, state of federal regulation for the industrial waste.



## 9. Hydraulic oil & grease

### 1) Hydraulic oil

The following working materials are required to operate the hydraulic hammer.

#### CAUTION

Only approved hydraulic oils should be used. All hydraulic oils recommended by the excavator manufacturer are suitable for hammer operation. Use of other hydraulic fluids is subject to approval.

Minimum viscosity 32 cSt  
Optimum viscosity 46-68 cSt

Check the oil temperature constantly to ensure it does not exceed 80°C(176°F). If higher temperatures are measured in the tank, an oil cooler must be fitted.

### 2) Grease : NLGI No.2

Shell Alvania EP2

Lithan EP2

Mobilplex 48

#### CAUTION

When using oil at an extremely cold or hot weather, it must be selected according to the application. Contact us or the service shop.

|                  |
|------------------|
| <b>ATTENTION</b> |
|------------------|

## 10. Maintenance Checking Schedule

| Item |                  | Inspection   |
|------|------------------|--|
| 1    | During the shift | .Lubricate the working steel 2 to 5 times per shift<br>(depending on the conditions)<br>.Check the Bolts<br>- bracket pin part<br>- bracket set bolt part<br>- power cell tension bolt part  |
| 2    | Daily            | .Tighten screw connections<br>.Hydraulic hose & piping leaks<br>.Pipe clamps still fit correctly<br>.Check bracket cracks<br>.Check spring pin & rubber plug   |
| 3    | Weekly           | .Tighten screw connections<br>.Adapter & fitting for wear<br>.Check spring pin & rubber plug<br>.Check impact surface of working steel for chips<br>.Check tool for crack  |
| 4    | Every 2 weeks    | .Check pressure accumulator & head cap<br>.Working steel for wear<br>.Check Tool Holder Bushing for wear<br>.Check Tool Holder Round Bushing for wear<br>.Check Bracket for wear<br>.Tighten screw<br>- Bracket: Pin part<br>- Power cell: Tension Bolt, Hose Adapter part<br>- Bracket : Set Bolt, Mounting Bolt part |
| 5    | Every month      | .Tighten screw<br>- Tension Bolt<br>- Swivel Cover Bolt<br>.Check wear & damage of Retainer Pin<br>.Check wear & damage of Bracket<br>.Overplus wear point<br>.Hydraulic Fluid, Nitrogen Gas leakage   |
| 6    | Every 6months    | .Change Seal in every 6 months<br>.Change Pads in Silent Housing in every 6 months   |

## ATTENTION

### VI. TROUBLE SHOOTING

Dismantle the hammer after releasing the gas from head cap. If the tension bolt is broken, all 4 bolts are to be checked for tight fitting. In case of the extension bolt of accumulator, all 4 bolts are to be checked, too.

#### . Hammer does not start

| Cause |   | Required action  |
|-------|---|--|
| 1     | Pressure and return lines have been mixed up                  | Connect them correctly   |
| 2     | Shut-off valve or return lines are close                      | Open shut-off valve  |
| 3     | Gas pressure in head cap too high.                            | Readjust nitrogen gas pressure   |
| 4     | Damaged screw couplings are blocking pressure or return lines | Replace with new one   |
| 5     | Defective electric system for hammer operation.               | Call authorized service man  |
| 6     | Defective magnet of valve switch                              | Replace magnet   |
| 7     | Operating pressure too low                                    | Inspect the engine speed of carrier and readjust the operating pressure. |
| 8     | Lack of hydraulic oil   | Fill hydraulic oil   |

#### .High frequency and low blow power

| Cause |   | Required action   |
|-------|---|-------------------|
| 1     | No gas in head cap:<br>Defective ring of the upper seal | Replace seal ring |
| 2     | O-ring is damaged                                       | Replace o-ring    |

#### .Working temperature is high.

| Cause |  | Required action  |
|-------|--|--|
| 1     | Oil is not sufficient  | Refill hydraulic oil                                   |
| 2     | Oil flow of the carrier to the hammer is excessive                 | Reduce the speed of the engine.<br>Adjust the oil pump |
| 3     | Oil temperature is high, but hammer is not connected to oil cooler | Connect to oil cooler                                  |
| 4     | Defective relief valve   | Replace with new relief cartridge                      |

#### .Low blow frequency

| Cause |  | Required action  |
|-------|--|--|
| 1     | Oil flow insufficient  | Adjust the speed of engine   |
| 2     | Couplings of hydraulic pipe lines are loose  | Tighten.   |
| 3     | Shut-off Valve is partially close.   | Open it fully  |
| 4     | Pressure in head cap is low  | Charge the gas and adjust the pressure.  |
| 5     | tool shank is seizing or<br>tool dose not work smoothly  | Check the surface of the Tool and Round Bushing. If the tool is seizing, repair with grinder |
| 6     | Oil temperature exceeds 80°C(186°F)  | Check and refill the hydraulic oil   |
| 7     | Flow resistance of oil filter and oil cooler are high  | Wash or replace oil filter and cooler  |
| 8     | Inner diameter of return line is small   | Replace return line more than 25mm of inner diameter   |
| 9     | Return pressure is high  | Check the pressure   |
| 10    | Return line connects to control valve.   | Return line must be connected directly to the oil tank or filter                             |
| 11    | Defective diaphragm of accumulator.<br>Lots of tremor of the hose can make damage at the entrance of hammer! | Replace the diaphragm  |
| 12    | Hydraulic oil pressure is low  | Check the pressure and if it is red, replace with new pressure relief cartridge.             |

#### .Oil leakage











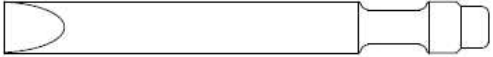

| Cause |   | Required action             |
|-------|---|-----------------------------|
| 1     | Shut-off valve is not open completely       | Open shut-off valve         |
| 2     | Defective couplings of hydraulic pipe lines | Replace couplings defected  |
| 3     | Poor main pump performance                  | Call authorized service man |

#### .Reduced blow power and frequency

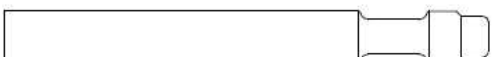
| Cause |  | Required action  |
|-------|--|--|
| 1     | Loose screw connection. Defective O-Ring | Tighten screw connection.<br>Replace with new one                    |
| 2     | Loose extension bolt of accumulator      | Replace O-ring and Back-up ring.<br>Tighten extension bolt           |
| 3     | Dust seal is worn                        | Replace seal and grease the tool every 2 or 3 hours during operation |

**VII. ACCESSORY PARTS LIST**

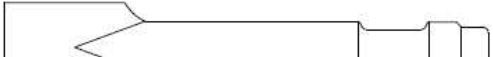
**1. Tool type and part list**

|   |   |   |
|---|---|---|
|    |    | A TYPE : MOIL TYPE<br>– Multiple Purpose                        |
|    |    | B TYPE : H WEDGE TYPE<br>–Trenching, Asphalt, Concrete          |
|    |    | C TYPE : CONE TYPE<br>– Multiple Purpose                        |
|    |    | D TYPE : BLUNT TYPE<br>– Boulders, Concrete                     |
|    |    | E TYPE : V WEDGE TYPE<br>– Trenching, Asphalt, Concrete         |
|    |    | F TYPE : SPADE H WEDGE TYPE<br>– Pavement, Soft rock, Hard Clay |
|  |  | G TYPE : SPADE V WEDGE TYPE<br>– Asphalt & Concrete, Pavement   |

**\* Tool Part Pcode List**

| Type   | A        | B        | C        | D        | E        | F       | G       |
|--------|----------|----------|----------|----------|----------|---------|---------|
|        | MOIL     | H-WEDGE  | CONE     | BLUNT    | V-WEDGE  | SPADE-H | SPADE-V |
| HK580S | DF000060 | DF000070 | DF000090 | DF000100 | DF000080 | -       | -       |

2. Union cap part list

| HOSE<br>SIZE | UNION CAP |          |           |
|--------------|-----------|----------|-----------|
|              | PF TYPE   | JIC TYPE | ORFS TYPE |
| 1¼           | 13007170  | 13007630 | 13007460  |

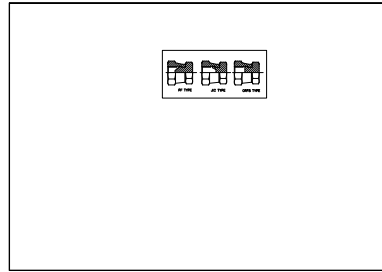

3. Hose plug part list

| HOSE<br>SIZE | PLUG, HOSE |          |           |
|--------------|------------|----------|-----------|
|              | PF TYPE    | JIC TYPE | ORFS TYPE |
| 1¼           | 13006590   | 13008430 | 13008260  |

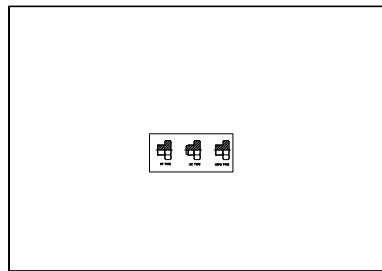

4. O-ring adapter part list

| HOSE<br>SIZE | O-RING ADAPTER |          |
|--------------|----------------|----------|
|              | PF*PF          | PF*JIC   |
| 1¼           | 130087870      | 13009360 |

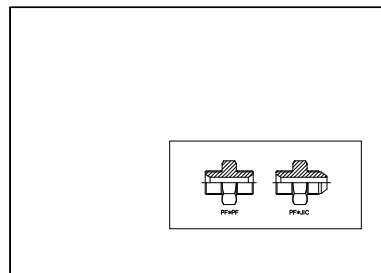

5. Base cover plate dimension

[unit : mm]

| MODEL  | A   | B   | C  | D   | E   | F   | G   | J  | DIA K |
|--------|-----|-----|----|-----|-----|-----|-----|----|-------|
| HK580S | 740 | 944 | 42 | 205 | 225 | 225 | 200 | 45 | 39    |

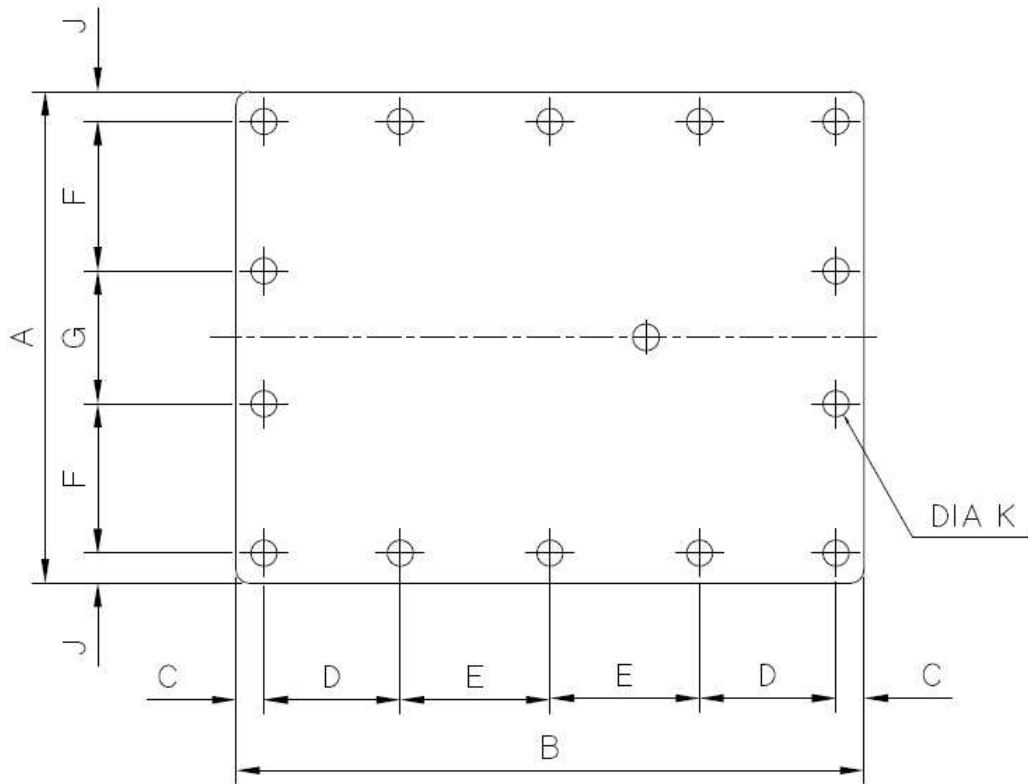

**ATTENTION**

**VIII. UNDERWATER KIT(OPTION)**

The hydraulic hammer should never be left in or underwater with the compressed air supply switched off. Without the compressed air supply, the cylinder will fill up with water, and it will then result in serious damage.

\* For under water operation, please contact to us.(option)

for UNDERWATER KIT

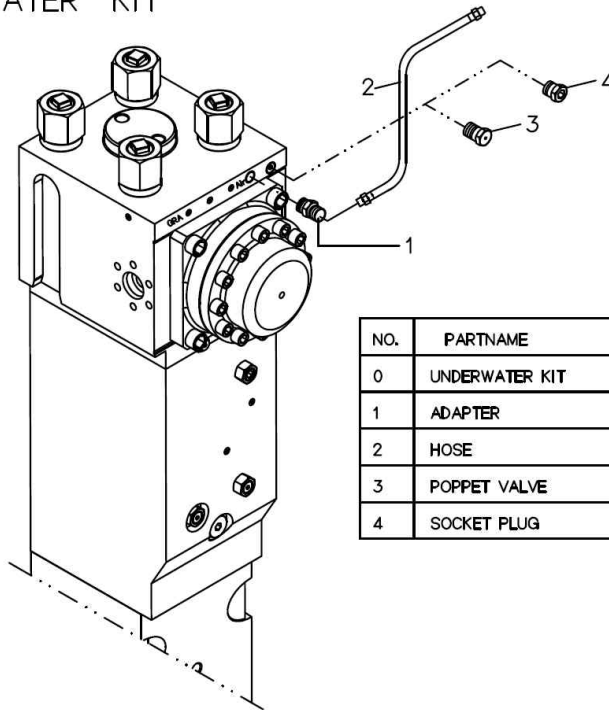

| NO. | PARTNAME       | Q'TY | REMARKS       |
|-----|----------------|------|---------------|
| 0   | UNDERWATER KIT | 1    |               |
| 1   | ADAPTER        | 1    | PT1/2" *PF1/2 |
| 2   | HOSE           | 1    | 1/2"          |
| 3   | POPPET VALVE   | 1    | REMOVE        |
| 4   | SOCKET PLUG    | 1    | ADD. ASSEMBLY |

Supply appropriate air flow rate in accordance with the hammer model and operating depth.

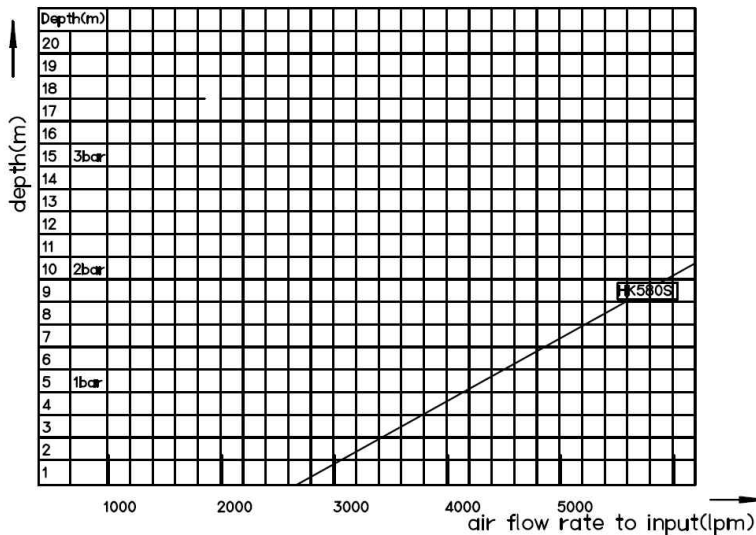



IX. AUTO LUBE KIT(OPTION)

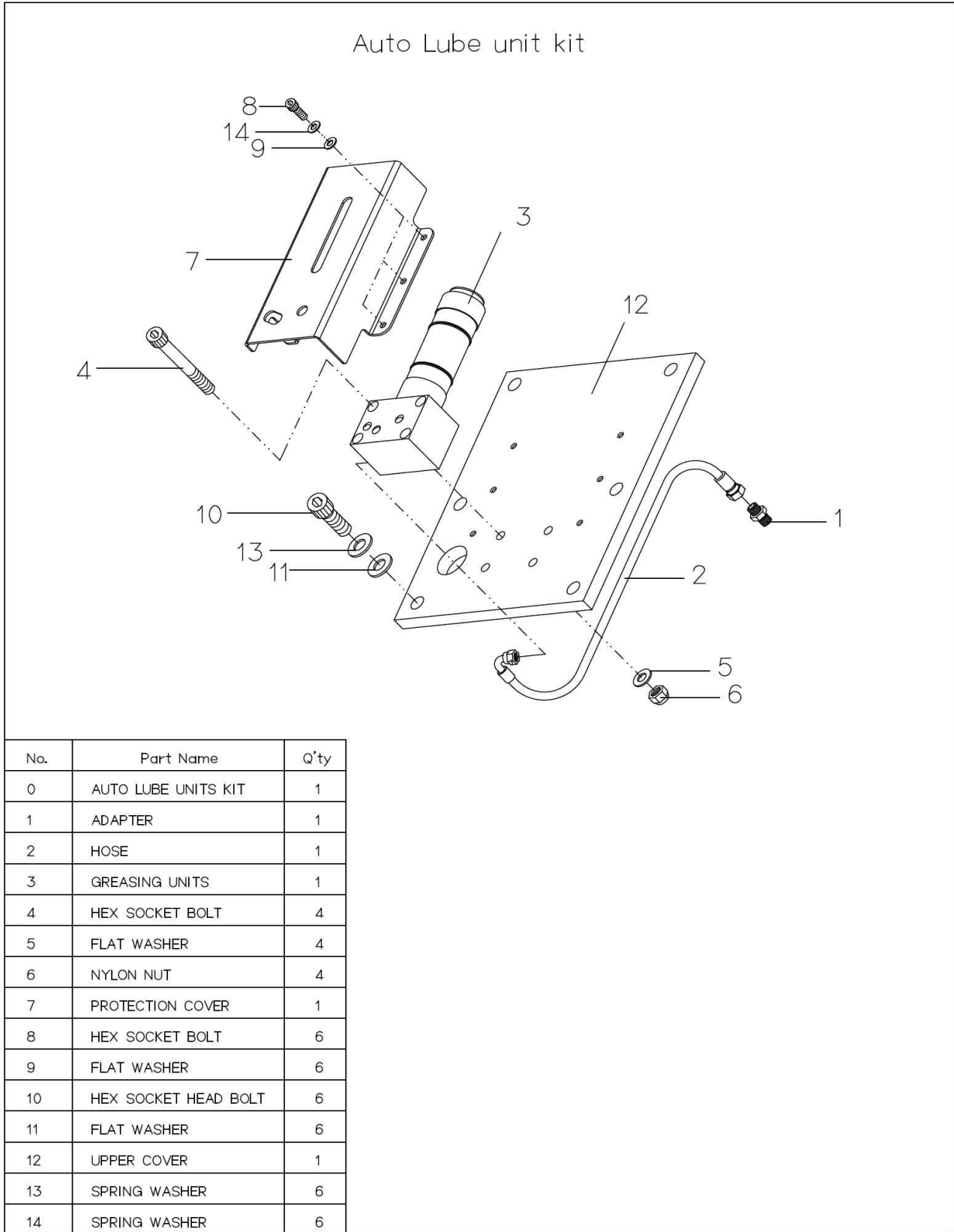

## X. WEAR PARTS AND JUDGEMENT - Tool

Tool is a wear parts and can also have various problems.

- 1) When damage occurs in the part where tool meets with Piston, the degree of abrasion on tool Holder Bushing and Round Bushing must be checked.  
In case Piston and tool are not genuine parts, damage can occur by the different hardness caused by different heating treatment(process).  
Free replacement will be made when choice goods are used in standard condition.
- 2) Tool will be replaced with no charge in case damage occurs in aperture of Retainer Pin.
- 3) Free replacement can not be made when damage occurs below Retainer Pin, which is below Tool Holder Bushing, since it is considered user's fault such as prying.
- 4) The manufacturing number of tool must be checked in order to make a claim.
- 5) The manufacturing number is on the side of aperture for Retainer Pin.
- 6) When problem occurs, the damaged area as well as the manufacturing number must be photographed and the damaged part must be collected and kept for evidence .

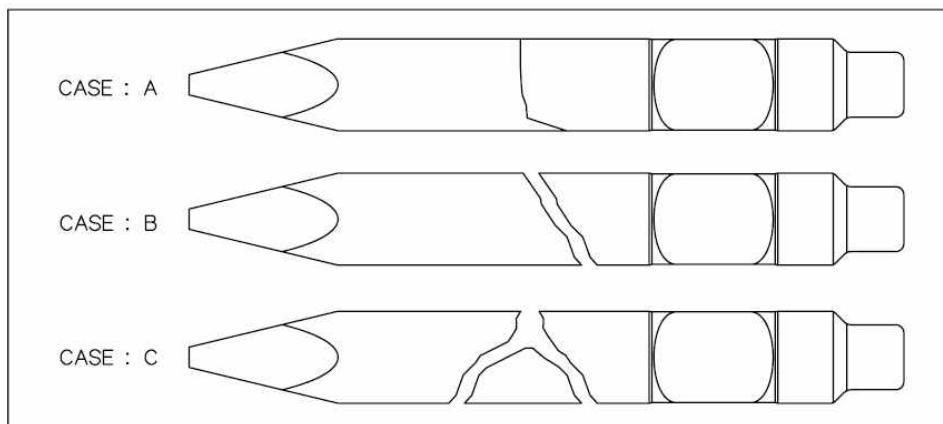

7) Claim can not be made in case of excessive abrasion of Tool.

- Vertical cuts
- Horizontal cuts
- Breakage of hitting parts
- Flatness of hitting parts

### (1) Charged Repair

Damage caused by using non genuine Piston or tool

Horizontal cuts below the joint with Retainer Pin

**Wear around the End Taper**

Damage occurring after using Flat type Tool more than 45mm of wear

Damage occurring after using Moil. H-Wedge, V-Wedge Type more than 75mm of wear

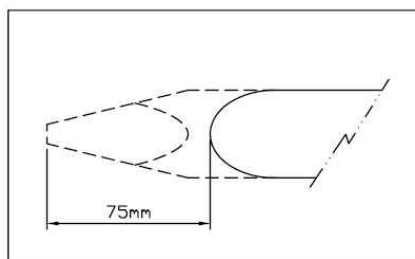
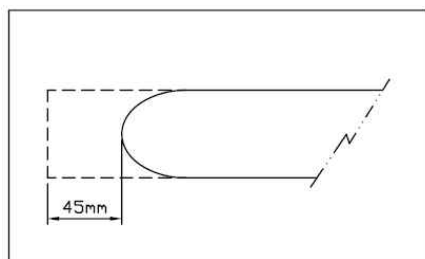

In case Tool is pushed in by continuous hitting on hard rocks

Damage to upper part of Tool by excessive abrasion of Tool Holder Bushing

**(2) Free Repair**

Breakage or flatness of upper hitting part of tool in normal usage condition

Damage to joint of Retainer Pin

Vertical cuts in Tool

**ATTENTION**

**(3) SEAL KIT : Oil Leaks, Tears, Cuts, Abrasion (Scratches), Hardening or Inverting of Seal Kit**

**Charged Repair**

Oil leaks due to excessive use of Seals without replacement

Hardening of Seals due to excessive rise of oil temperature ( over 80°C )

Discoloration of Seals to dark brown

Scratches on Seals due to inflow of particles

Damage caused by not carrying on warming ups in the beginning of operating Hammer

Inverted Seals

**Free Repair**

Oil leaks or Gas leaks when Piston and Cylinder are normal



# BHI Hydro**Ram** Hydraulic Hammer

## HK580S Parts List

HK580S POWER CELL

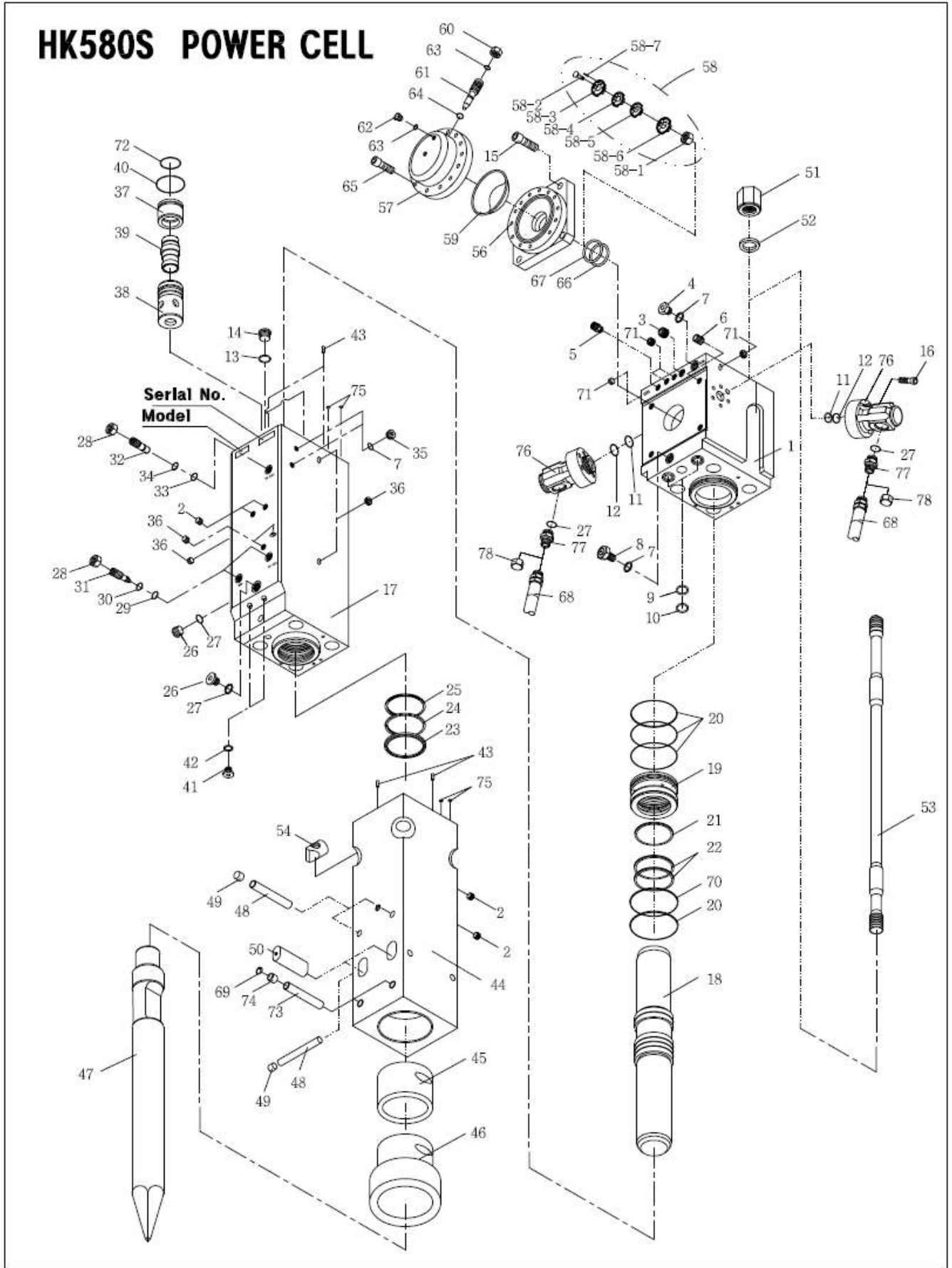

## ■ HK580S POWER CELL

| No. | Part No. | Part Name            | Q'ty | No.  | Part No. | Part Name   | Q'ty |
|-----|----------|----------------------|------|------|----------|---|------|
| 0   | DM000000 | POWER CELL ASSEMBLY  | 1    | 30   | 22405610 | BACK UP RING                                      | 2    |
| 1   | DM000200 | HEAD CAP             | 1    | 31   | DL000230 | CYLINDER ADJUSTER                                 | 2    |
| 2   | 13006030 | PT SOCKET PLUG       | 4    | 32   | DF000590 | ADJUSTER VALVE                                    | 1    |
| 3   | 13006020 | PT SOCKET PLUG       | 1    | 33   | 22402060 | O-RING  | 1    |
| 4   | DK000080 | POPPET VALVE         | 1    | 34   | 22405650 | BACK UP RING                                      | 1    |
| 5   | 13009210 | ELBOW ADAPTER        | 1    | 35   | DA000400 | PF SOCKET PLUG                                    | 2    |
| 6   | 13102960 | HELI COIL SPRING     | 4    | 36   | 13006010 | PT SOCKET PLUG                                    | 5    |
| 7   | 22402070 | O-RING               | 4    | 37   | DF000570 | MAIN VALVE CAP                                    | 1    |
| 8   | D7000200 | GAS VALVE ASSEMBLY   | 1    | 38   | DF000580 | MAIN VALVE CASE                                   | 1    |
| 9   | 22402350 | O-RING               | 2    | 39   | DF000560 | MAIN VALVE  | 1    |
| 10  | 22409410 | BACK UP RING         | 2    | 40   | 22401440 | O-RING  | 1    |
| 11  | 22401370 | O-RING               | 2    | 41   | DH000380 | PF SOCKET PLUG                                    | 2    |
| 12  | 22406730 | BACK UP RING         | 2    | 42   | 22402000 | O-RING  | 2    |
| 13  | 22402210 | O-RING               | 4    | 43   | D9000050 | PIN   | 4    |
| 14  | DF000050 | M36 SOCKET PLUG      | 4    | 44   | DM000220 | TOOL HOLDEER                                      | 1    |
| 15  | 20215090 | HEX SOCKET HEAD BOLT | 4    | 45   | DF000230 | ROUND BUSHING                                     | 1    |
| 16  | 20211760 | HEX SOCKET HEAD BOLT | 10   | 45-1 | DF001210 | ROUND BUSHING<br>(Oversized (+0.08~+0.1mm))       | 1    |
| 17  | DM000210 | CYLINDER             | 1    | 46   | DM000060 | TOOL HOLDER BUSHING                               | 1    |
| 18  | DM000250 | PISTON               | 1    | 46-1 | DM000300 | TOOL HOLDER BUSHING<br>(Oversized (+0.08~+0.1mm)) | 1    |
| 19  | DF000370 | CYLINDER BUSHING     | 1    | 47   | DF000060 | TOOL(MOIL)  | 1    |
| 20  | 22401690 | O-RING               | 4    | 47-1 | DF000070 | TOOL(H WEDGE)                                     | -    |
| 21  | 22200110 | GAS SEAL             | 1    | 47-2 | DF000090 | TOOL(CONE)  | -    |
| 22  | 22300100 | STEP SEAL            | 2    | 47-3 | DF000100 | TOOL(BLUNT)                                       | -    |
| 23  | 22002760 | DUST SEAL            | 1    | 47-4 | DF000080 | TOOL(V WEDGE)                                     | -    |
| 24  | 22004020 | U PACKING            | 1    | 48   | DF000360 | STOP PIN(B)                                       | 3    |
| 25  | 22000270 | BUFFER SEAL          | 1    | 49   | 13007350 | RUBBER PLUG                                       | 3    |
| 26  | 13100370 | PF SOCKET PLUG       | 2    | 50   | DM000080 | RETAINER PIN                                      | 2    |
| 27  | 22402260 | O-RING               | 4    | 51   | DF000780 | TOP NUT   | 4    |
| 28  | 12002410 | HEX HEAD NUT         | 3    | 52   | DF000770 | TOP NUT WASHER                                    | 4    |
| 29  | 22402020 | O-RING               | 2    | 53   | DM000040 | TENSION BOLT                                      | 4    |

■ HK580S POWER CELL

| No.  | Part No. | Part Name            | Q'ty | No.  | Part No. | Part Name        | Q'ty |
|------|----------|----------------------|------|------|----------|------------------|------|
| 54   | DM000050 | BOTTOM NUT           | 4    | 1    | DM691010 | HEAD CAP SET     | 1    |
| 55   | DF000670 | ACCUMULATOR ASSEMBLY | 1    | 2    | DM691110 | CYLINDER SET     | 1    |
| 56   | DF000660 | ACCUMULATOR BODY     | 1    | 3    | DM691210 | TOOL HOLDER SET  | 1    |
| 57   | DF000650 | ACCUMULATOR COVER    | 1    | 4    | DF691300 | MAIN VALVE SET   | 1    |
| 58   | DF692300 | ACC. ORIFICE SET     | 1    | 5    | DM691400 | TENSION BOLT SET | 1    |
| 58-1 | DA000440 | LOCK NUT             | 1    | MEMO |          |                  |      |
| 58-2 | DF000680 | ORIFICE(A)           | 1    |      |          |                  |      |
| 58-3 | DF000690 | ORIFICE(B)           | 1    |      |          |                  |      |
| 58-4 | DF000700 | ORIFICE(C)           | 1    |      |          |                  |      |
| 58-5 | DF000710 | ORIFICE(D)           | 1    |      |          |                  |      |
| 58-6 | DF000720 | ORIFICE(E)           | 1    |      |          |                  |      |
| 58-7 | DF000730 | HOLDER PIN           | 1    |      |          |                  |      |
| 59   | DF000740 | DIAPHRAGM            | 1    |      |          |                  |      |
| 60   | DC000320 | O-RING PLUG          | 1    |      |          |                  |      |
| 61   | DC000330 | CHARGING VALVE       | 1    |      |          |                  |      |
| 62   | DA000510 | O-RING CAP           | 1    |      |          |                  |      |
| 63   | 22402040 | O-RING               | 2    |      |          |                  |      |
| 64   | 22401930 | O-RING               | 1    |      |          |                  |      |
| 65   | 20215070 | HEX SOCKET HEAD BOLT | 16   |      |          |                  |      |
| 66   | 22402550 | O-RING               | 1    |      |          |                  |      |
| 67   | 22409610 | BACK UP RING         | 1    |      |          |                  |      |
| 68   | 16804760 | SPRING HOSE          | 2    |      |          |                  |      |
| 69   | 13003160 | SNAP RING            | 2    |      |          |                  |      |
| 70   | DF000390 | BUFFER RING SEAL     | 1    |      |          |                  |      |
| 71   | 13006060 | PT SOCKET PLUG       | 4    |      |          |                  |      |
| 72   | 22401410 | O-RING               | 1    |      |          |                  |      |
| 73   | DF000330 | STOP PIN(A)          | 2    |      |          |                  |      |
| 74   | 13007340 | RUBBER PLUG          | 2    |      |          |                  |      |
| 75   | 22402080 | O-RING               | 4    |      |          |                  |      |
| 76   | DK000400 | IN-OUT FLANGE        | 2    |      |          |                  |      |
| 77   | 13009750 | O-RING ADAPTER       | 2    |      |          |                  |      |
| 78   | 13007050 | UNION CAP            | 2    |      |          |                  |      |

## ■ HK580S SPARE SEAL KIT

| No.  | Part No. | Part Name        | Q'ty | MEMO |
|------|----------|------------------|------|------|
| 0    | DM691510 | SPARE SEAL KIT   | 1    |      |
| 1    | 22402070 | O-RING           | 4    |      |
| 2    | 22402350 | O-RING           | 2    |      |
| 3    | 22409410 | BACK UP RING     | 2    |      |
| 4    | 22401370 | O-RING           | 2    |      |
| 5    | 22406730 | BACK UP RING     | 2    |      |
| 6    | 22402210 | O-RING           | 4    |      |
| 7    | 22401690 | O-RING           | 4    |      |
| 8    | 22200110 | GAS SEAL         | 1    |      |
| 9    | 22300100 | STEP SEAL        | 2    |      |
| 10   | 22002760 | DUST SEAL        | 1    |      |
| 11   | 22004020 | U PACKING        | 1    |      |
| 12   | 22000270 | BUFFER SEAL      | 1    |      |
| 13   | 22402260 | O-RING           | 4    |      |
| 14   | 22402020 | O-RING           | 2    |      |
| 15   | 22405610 | BACK UP RING     | 2    |      |
| 16   | 22402060 | O-RING           | 1    |      |
| 17   | 22405650 | BACK UP RING     | 1    |      |
| 18   | 22401440 | O-RING           | 1    |      |
| 19   | 22402000 | O-RING           | 2    |      |
| 20   | 22402040 | O-RING           | 2    |      |
| 21   | 22401930 | O-RING           | 1    |      |
| 22   | 22402550 | O-RING           | 1    |      |
| 23   | 22409610 | BACK UP RING     | 1    |      |
| 24   | DF000390 | BUFFER RING SEAL | 1    |      |
| 25   | 22401410 | O-RING           | 1    |      |
| 26   | 22402080 | O-RING           | 4    |      |
| -    | -        | -                | -    |      |
| MEMO |          |                  |      |      |



### ■ HK580S TOOL KIT

| No. | Part No. | Part Name           | Q'ty | Remarks         |
|-----|----------|---------------------|------|-----------------|
| 0   | DM691800 | TOOL KIT            | 1    | HK580S          |
| 1   | 16502990 | TOOL BOX            | 1    | No. 1           |
| 2   | 16500260 | COMBI SPANNER       | 1    | 14mm            |
| 3   | 16500370 | COMBI SPANNER       | 1    | 32mm            |
| 4   | 16502580 | SINGLE SPANNER      | 1    | 50mm            |
| 5   | 16502100 | DOUBLE SPANNER      | 1    | 27x30mm         |
| 6   | 16501140 | L WRENCH            | 1    | 5mm             |
| 7   | 16501180 | L WRENCH            | 1    | 12mm            |
| 8   | 16501190 | L WRENCH            | 1    | 14mm            |
| 9   | 16501210 | L WRENCH            | 1    | 19mm            |
| 10  | 16501230 | L WRENCH            | 1    | 24mm ( OPTION ) |
| 11  | 16500780 | HAMMER RING WRENCH  | 1    | 80mm            |
| 12  | 16503090 | HANDLE RETAINER PIN | 1    | M12             |
| 13  | 16500730 | HAMMER RING WRENCH  | 1    | 55mm            |

### ■ HK580S N2 GAS CHARGING KIT

| No. | Part No. | Part Name                               | Q'ty | MEMO |
|-----|----------|---|------|------|
| 0   | DA698000 | N <sub>2</sub> GAS CHARGING KIT         | 1    |      |
| 1   | 13105900 | N <sub>2</sub> GAS 3-WAY VALVE ASSEMBLY | 1    |      |
| 2   | 16802000 | N <sub>2</sub> HOSE                     | 1    |      |
| 3   | 13105910 | N <sub>2</sub> COUPLING KIT             | 1    |      |
| 4   | 13105920 | N <sub>2</sub> GAS CYLINDER             | 1    |      |

■ HK580S BRACKET

# HK580S

## HK580S BRACKET

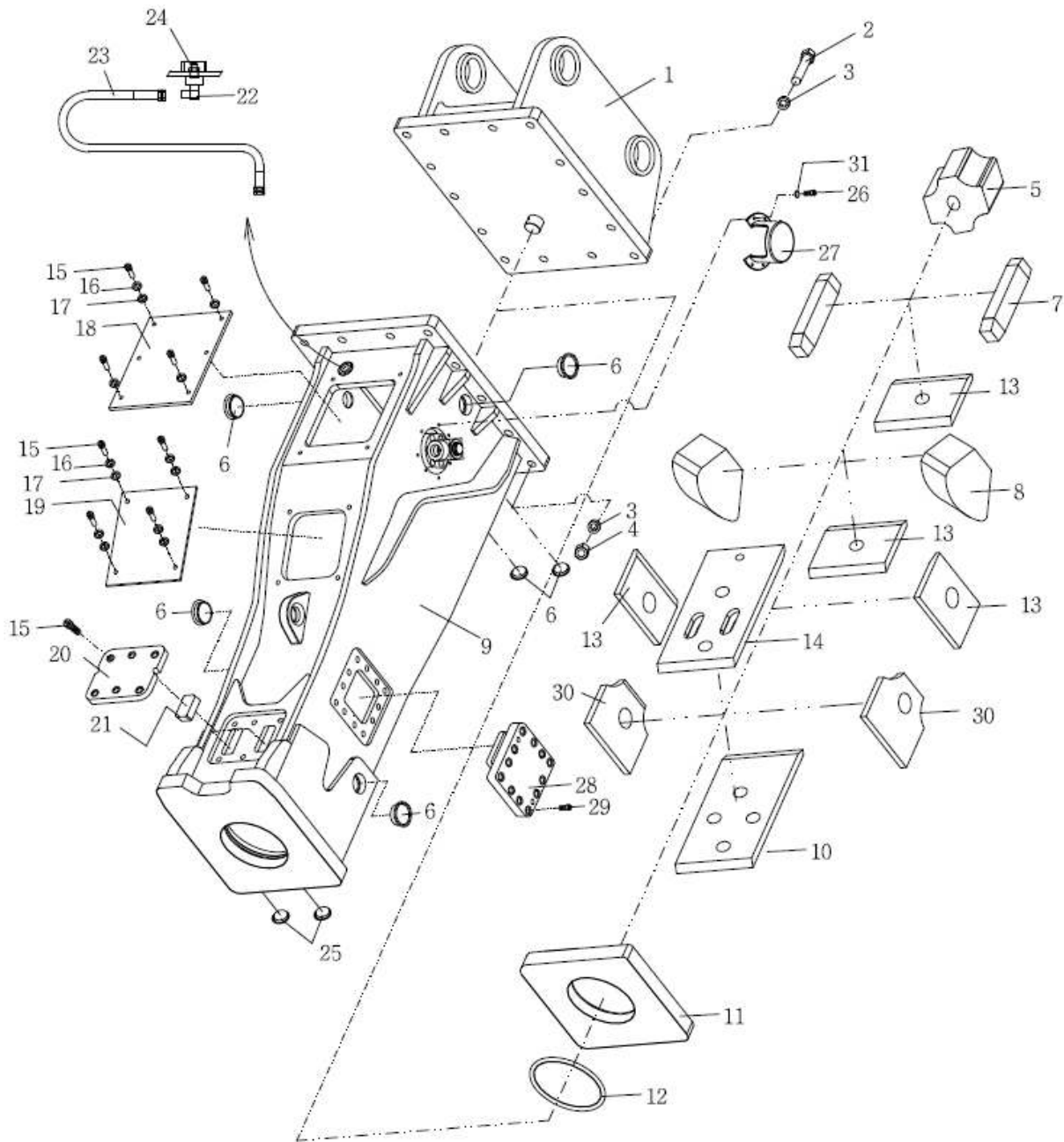

## ■ HK580S BRACKET

| ■HK580S BRACKET |          |                          |      | ■HK580S BRACKET |          |                      |      |
|-----------------|----------|--------------------------|------|-----------------|----------|----------------------|------|
| No.             | Part No. | Part Name                | Q'ty | No.             | Part No. | Part Name            | Q'ty |
| 0               | DM300000 | SILENCE BRACKET ASSEMBLY | 1    | 28              | DM300210 | SIDE DAMPER          | 2    |
| 1               | DM300020 | TOP BRACKET              | 1    | 29              | 20212090 | HEX SOCKET HEAD BOLT | 24   |
| 2               | 20009850 | HEX HEAD BOLT            | 14   | 30              | DM300150 | SIDE WEAR PLATE      | 2    |
| 3               | 13000150 | FLAT WASHER              | 28   | 31              | 13000060 | FLAT WASHER          | 10   |
| 4               | 12006460 | NYLON NUT                | 14   | -               | DM695200 | DECAL KIT            | 1    |
| 5               | DM300090 | UPPER CUSHION            | 1    | MEMO            |          |                      |      |
| 6               | D9300070 | RUBBER CAP-S             | 6    |                 |          |                      |      |
| 7               | DK300110 | SIDE PAD                 | 2    |                 |          |                      |      |
| 8               | DM300110 | SIDE CUSHION             | 2    |                 |          |                      |      |
| 9               | DM300010 | SILENCE BRACKET BODY     | 1    |                 |          |                      |      |
| 10              | DM300140 | BACK WEAR PLATE          | 1    |                 |          |                      |      |
| 11              | DM300100 | DOWN CUSHION             | 1    |                 |          |                      |      |
| 12              | DM300120 | DUST PROTECTION SEAL     | 1    |                 |          |                      |      |
| 13              | DM300070 | DOWN WEAR PLATE          | 4    |                 |          |                      |      |
| 14              | DM300130 | FRONT WEAR PLATE         | 1    |                 |          |                      |      |
| 15              | 20212470 | HEX SOCKET HEAD BOLT     | 16   |                 |          |                      |      |
| 16              | 13001100 | SPRING WASHER            | 10   |                 |          |                      |      |
| 17              | 13000100 | FLAT WASHER              | 10   |                 |          |                      |      |
| 18              | DM300200 | UPPER COVER              | 1    |                 |          |                      |      |
| 19              | DM300240 | DOWN COVER               | 1    |                 |          |                      |      |
| 20              | DM300030 | RETAINER PIN COVER       | 1    |                 |          |                      |      |
| 21              | DL300060 | RETAINER PIN CUSHION     | 2    |                 |          |                      |      |
| 22              | 13009200 | ELBOW ADAPTER            | 2    |                 |          |                      |      |
| 23              | DK300140 | HOSE                     | 1    |                 |          |                      |      |
| 24              | 13007810 | GREASE NIPPLE            | 1    |                 |          |                      |      |
| 25              | DK300160 | RUBBER PLUG              | 2    |                 |          |                      |      |
| 26              | 20211050 | HEX SOCKET BOLT          | 10   |                 |          |                      |      |
| 27              | DK300170 | IN-OUT FLANGE COVER      | 2    |                 |          |                      |      |